

**INSTALLATION & OPERATION
MANUAL
Plasma Blo₃ck**

600g



Appnote Plasma Block 600g A2
6/10/19

TABLE OF CONTENTS

	PAGE
Design Features	
Section 1 Warranty	3
Section 2 Safety Considerations	4
Section 3 Visual Product Overview	5
Section 4 General Installation	6
Section 5 Startup	10
Section 6 Shutdown	12
Section 7 Technical Support	13
Section 8 Maintenance and Return Procedure	14
Section 9 Specs and Features	15
Section 10 Performance Graphs	16
Section 11 Product Dimensions	18
Section 12 Wiring Diagram and Connections	20
Section 13 Install Options	23

Please refer to the DAT 210 manual for inverter specific installation and operational details. Refer to the PlasmaBlock® Application Guide for installation tips. Both are available on the PTI website at <http://www.plasmatechnics.com> under the support tab.

Section 1 Warranty

PTI Plasma Block® Limited Warranty

The PTI Plasma Block® unit is warranted by Plasma Technics, Inc®, to the original purchaser to be free from defects in material and workmanship under normal use and service for a period of **FOUR (4) years** from the date of purchase under the following terms and conditions:

The obligation of Plasma Technics, Inc®. is expressly limited to repairing or replacing, at the option of Plasma Technics, Inc®, any PTI Plasma Block® returned to it during the warranty period, which is determined by PTI to be defective in material or workmanship.

Any improper use /operation or installation other than in accordance with the published application materials, instructions and specifications established by Plasma Technics, Inc.® shall void this warranty.

The obligation of Plasma Technics, Inc®. Shall not include any transportation charges, costs of removal or installation, labor charges or any direct, indirect, consequential or delay damages.

Attachment or use of components or accessories not compatible with the PTI Plasma Block® shall void this warranty.

Any alteration not authorized by Plasma Technics, Inc. in writing, accident, misuse, abuse or damage to the PTI Plasma Block® shall void this warranty.

The Plasma Block® subject to this warranty is not warranted as suitable for any particular purpose or use of the purchaser. The suitability of any PTI Plasma Block® for any purpose particular to the purchaser is for the purchaser in the purchaser's sole judgment, to determine. Plasma Technics, Inc®. assumes no responsibility for the selection or furnishing of a Plasma Block® suitable to the purchaser's needs or the purposes of any particular purchaser.

This warranty is in lieu of any other warranty express or implied, including specifically but without limitation warranties of merchantability or efficacy and of all other obligations or liabilities in connection with the sale or use of the PTI Plasma Block®.

Section 2 Safety Considerations

Oxygen is a fire hazard.

Exposure to ozone should be limited (ozone has a distinctive odor).

Ozone is a toxic oxidizer, use of it should be controlled.

Ozone generators have high voltage and high capacitance.

Due to these considerations, only experienced individuals should be allowed to operate and work on this equipment.

DANGEROUS VOLTAGES ARE ON THIS CIRCUIT BOARD

To avoid injury to personnel and/or damage to equipment only qualified personnel should perform the procedures outlined in this chapter. This person must understand both the electrical and mechanical components associated with the application.

Thoroughly read and understand the following procedures before beginning the start-up process.

The following specific safety procedures must be observed when performing any maintenance or adjustments on the amplifier.

Always turn off and lock out AC power at the main machine disconnects switch. Do this before touching any electrical or mechanical components.

High voltage may be present even with all electrical power supplies disconnected.

Use an appropriate meter to verify that all DC bus capacitor banks have been discharged before working on any equipment. Do not rely exclusively on high voltage RED LED indicator for bus voltage, as dangerous voltage levels may remain even when the indicator is off.

Follow industry recognized safety procedures. Use only one hand to hold test equipment probes, wear approved eye protection, etc. Before energizing the inverter, make sure that device(s) connected to the output of the inverter will not result in injury or damage to equipment. Keep unnecessary personnel out of the immediate work area. Never leave an inverter cabinet open and unattended.

Section 3 Visual Product Overview

Visual Product Overview 600g

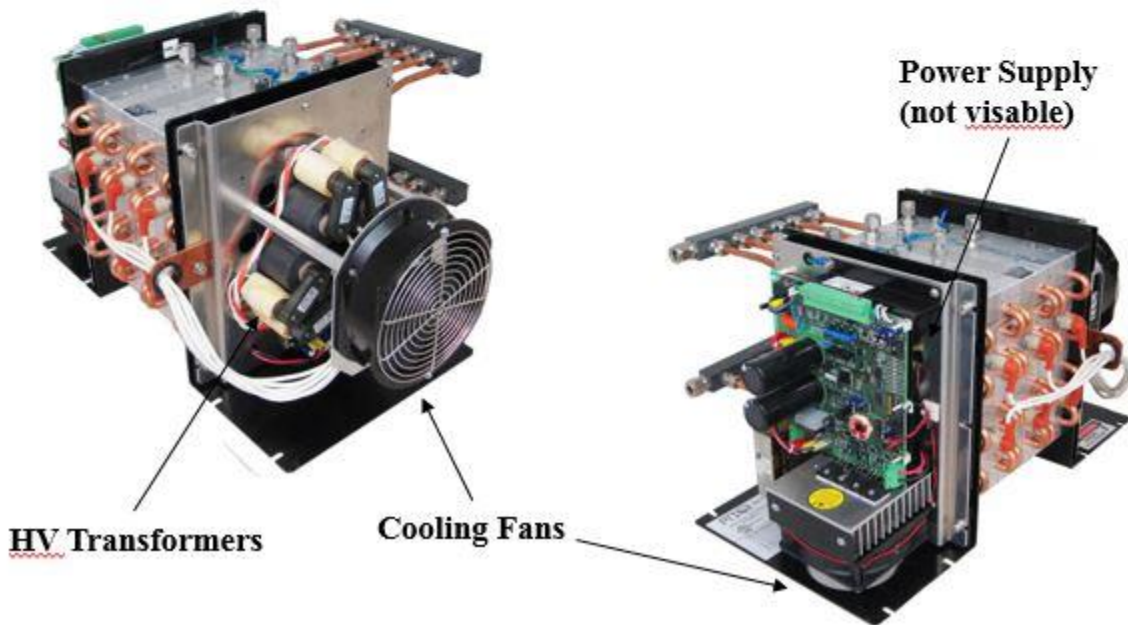
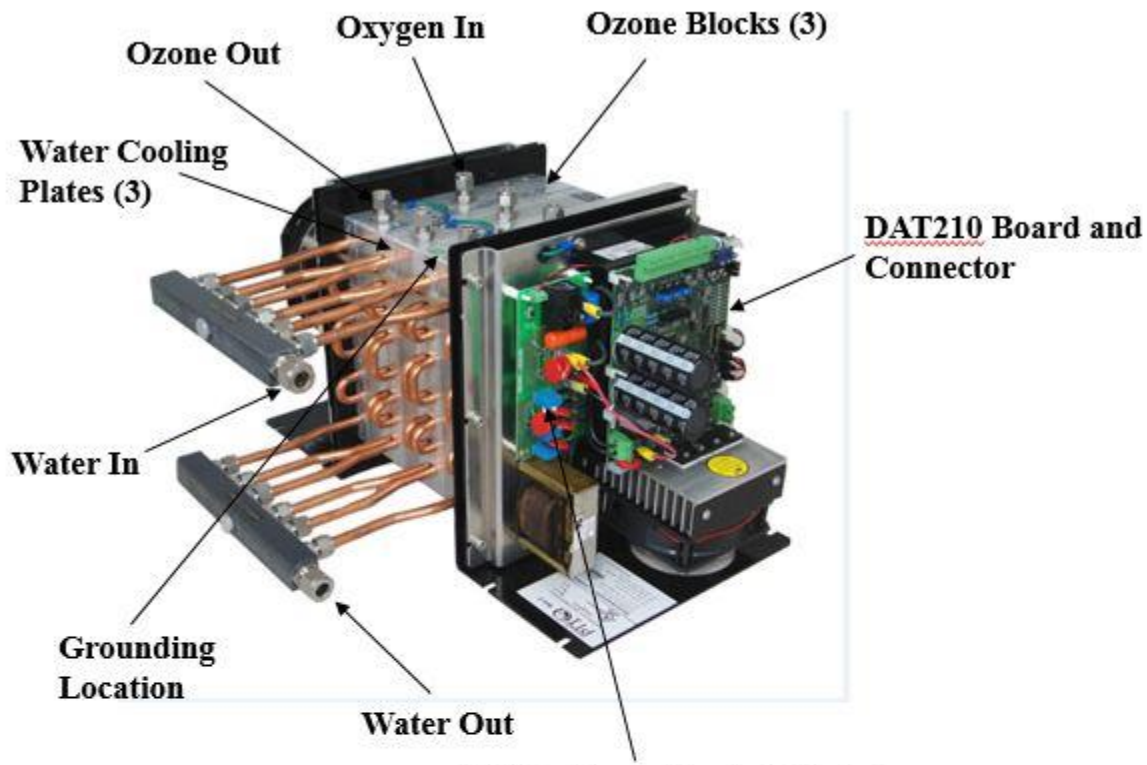

Section 4 General Installation

General Mounting Requirements

1. Mount to allow O₂ flow meters to work for user feedback. The assembly contains a cooling fan which cools the transformers. Allow 1.25” to 1.5” clearance between the top of the fan and an enclosure surface.
2. Read the nameplate for operating line voltage and current adjustment levels. **Use copper conductors only.**
3. Apply only the line voltage indicated on the nameplate.
4. Ground the plate assembly to service green utilizing star washer. **See installation drawing on the product drawings for possible grounding locations and High Voltage safety considerations..**
5. It is **important** to at least **verify** that the **system is set to the proper pressure**. If the pressure is below 2 psi **DO NOT** apply power. A vacuum condition in the generator cell will cause it to fail.
6. Since the generator is set up for maximum power under varying conditions of mains voltage and gas pressure or flow, if the mains power specified for this generator varies by more than 10% at full load, the inverter must be readjusted as shown in the DAT210 manual.

Refer to the "PTI General Application Guide" at www.plasmatechnics.com Support Tab for additional installation drawings and schematics.

Mounting Environment

The block should be mounted in an environment that is **free** from the following:

- Corrosive or volatile vapors
- Dust and particles
- Excessive moisture
- Shock, Excessive vibration
- Temperature extremes

The following environmental specifications apply:

Relative humidity: 5 to 90%, non-condensing. Altitude (maximum): 3,310 ft (1,000 m), de-rating for altitude is 1% for every 300 ft (100m) above 3000 ft (1000m).

Mounting can be in **any axis**.

Connect oxygen feed gas to port labeled INLET. OUTLET should have a flow restriction control downstream to produce an operating pressure range of 5 to 100psi. Oxygen feed should be filtered (.1 microns or less). There should be a pressure sensor on the oxygen INLET and ozone OUTLET lines to assure a positive pressure at all times. The Plasma Block unit should NOT be engaged if positive pressure is not present.

Allow 1” (2.5 cm) **MINIMUM** of space around the fan and areas which vent cooling air. 2” (5 cm) is better.

Surrounding air ambient operating temperature: 0° to 40° C (32° to 104° F)

No heat inducing stray fields are to be present within 3 feet (1 M) of the unit. These fields can radiate from large motors or large power supplies in the KW range.

Wiring Standards and Codes

The installation person is responsible for following the wiring plan produced by the design engineer for the specific application.

All wiring must conform to the following standards:

National Electrical Code, Publication NFPA No. 70.

All local and national codes which apply. For motor usage; use appropriate NEMA relay for protection.

See Section 9 for electrical operating specifications.

The supplier cannot assume responsibility for the compliance or noncompliance to any code governing the proper installation of this equipment.

Electrical Connection Wire Sizing and Fusing

Refer to the Plasma Block® Current/Power Measurement Table on the PTI web site [http://www.plasmatechnics.com/products/support/general-support-and-maintenance-links/Plasma Block Current Power Table](http://www.plasmatechnics.com/products/support/general-support-and-maintenance-links/Plasma%20Block%20Current%20Power%20Table)

See graphs for complete power adjustment data. Use branch circuit fuses suitable for use on a circuit capable of delivering not more than 20 A RMS Slo-Blo, 250 volts maximum. Refer to the National Electrical Code [NEC], Publication NFPA No. 70, Article 310, and any local codes that may apply for wire sizing and selection. Use 60/75°C wire min. Use copper conductors only.

Terminal connection max torque .37 inch lbs [0.5 newton meters (Nm)].

See Section 9 for electrical operating specifications.

Case Ground

Each of the blocks must be connected to ground at their case ground terminal. A grounding electrode conductor or bonding jumper must be connected from the ground terminal to either a grounding electrode buried in the earth or a suitable plant ground with solid connections to earth ground. Refer to NFPA No. 70, Article 250, for details on grounding and grounding electrodes.

Safety Grounding

The case ground connections should be made at the ground terminals. The case ground of the various system components should be connected to the star grounding bus of the cabinet. A grounding electrode conductor or bonding jumper must be connected from the star grounding bus to either a grounding electrode buried in the earth or a suitable plant ground with solid connections to earth ground. Refer to NFPA No. 70, Article 250, for details on grounding and grounding electrodes.

The only external connections for control needed are the ON/OFF switch. Note that an OFF contact closure will shut off the inverter even if the ON contact is made. The OFF contact takes priority.

All adjustments can be made on the inverter as shown with the jumper positions shown at the INTERNAL CONTROL position. Both VOLTAGE and FREQUENCY are pre-adjusted to your purchase order specifications. Power adjustment is only by the PDM potentiometer for normal operation range 0 – 100%. PDM may be changed from 0 – 10 VDC to 4 – 20 ma. for ozone output control in your final equipment. See the inverter jumper chart in the inverter manual.

At 240 VAC FLA is 10.7 Amps.

There MUST be a green wire earth ground from the chassis to conduit ground. This is an important safety and reliability feature.

General Operating Considerations

Refer to the Plasma Block® Current/Power Measurement Table for the proper electrical environment for each product. The table is in the support section on the PTI web site at www.plasmatechnics.com.

1. When AC power is applied, an inrush will occur - this is normal. A typical system will require a 10-amp circuit breaker. If the inverter line voltage will be turned on frequently the relay or switch should be amply sized to prolong its life due to the high inrush current. A soft charge circuit is recommended in this case and can be found in the DAT210 operator's manual. This will also extend the life of the DAT210. A soft start is needed with 3 phase.
2. The Plasma Block® is built with aluminum and ceramic. While aluminum provides maximum safety for applications like water purification, it does react with nitric acid that would be produced if atmospheric air were to be used rather than a concentrate for gas feed. For this reason **ONLY a concentrator or O₂ can be used to provide the feed gas.** To maintain the warranty the feed gas must be at least -60°F dew point and 93% O₂ or more.

3. Important Plasma Block Differences

	Internal clearances	Internal metallurgy	Optimal operating psi
Gen1	standard	none	10 - 20
Gen1 Enhanced	greater than standard	special	10 or less
Gen2	less than standard	special	20 - 30

4. **BEFORE** the system is energized for the first time the Plasma Block® should be pre-dried by flowing the above feed gas for 3 to 5 minutes. If the installed system will be dormant for long intervals then the control system should do a pre-purge to insure the system is dry before power is applied to the cell.
5. **AFTER when a system is off for an extended period, it is very important to prevent backflow** of liquids and gasses through the cell. Backflows void the cell warranty. For example, systems which use a venturi and concentrator must contain a solenoid valve to block gas flow if it is possible that the venturi will be active while the concentrator is off. Purge the unit/cell of all ozone whether turned off for a short or extended period of time.
6. When the Block requires servicing, return it to the factory - DO NOT disassemble. The Plasma Block® is fitted with a tamper label. If the label is broken, the warranty is void.
7. **While it is possible to configure the system to accommodate negative pressures, negative pressures are problematic and tend to cause large power and ozone fluctuations. The most stable and predictable systems occur at positive pressures.**

The ozone outlet fitting mounted into the plasma block® mates with other fittings inside of the unit and **must not be removed or changed** to another fitting type. Contact the factory if other sizes or styles are required.

Section 5 Startup

Start-up Checklist

To ensure a complete checkout and test, check off each step as it is completed. If the proper event does not occur while performing this start-up procedure, do not continue. Take the appropriate action to correct the malfunction before proceeding.

- Ensure the main disconnect switch is locked off. High voltage may be present even with all electrical power supplies are disconnected. Use an appropriate meter to verify that all DC bus capacitor banks have been discharged before working on any equipment. Do not rely exclusively on RED LED indicator of bus voltage, as dangerous voltage levels may remain even when indicator is off.
- Verify that the inverter mounting has been performed in accordance with the guidelines listed in Section 1.
- Inspect the inverter to verify that all optional modules have been selected and installed according to the system drawings and documentation.
- Verify that all wiring has been installed according to the wiring plan produced by the design engineer and according to the guidelines listed in Section 2 for proper connection, grounding, wire size, labeling, routing and applicable codes. The DAT210 does not have internal fusing. Install input and output (optional) fusing per suggestions in the DAT210 manual (Section 7).
- Verify that all electrical terminals, screws, nuts, and bolts are securely fastened.
- Apply high voltage DC or single-phase AC power to the inverter as specified.
- Check to make sure that the RED Bus voltage LED is on, indicating bus voltage.
- There is an inherent pressure drop associated with each Plasma Block. This can vary depending on the desired flow. Verification of the outlet pressure, at the desired flow, of the Plasma Block is crucial in order to prevent a negative pressure drop in the Plasma Block. This will damage the Plasma Block internals and is not a warrantied repair.

Start Up and Changing the factory power configuration (If needed)

Reasons for changing the factory setup:

By altering the 'Voltage' setting, you can easily modify the full power operational point if need be. Remember that the purpose of the PDM control is to provide a turndown from the 100% power set-point established by the **VOLTAGE** pot. The goals are 1) Maximum power and 2) Current High/Low limits. Adjustment is very easy.

If it is determined that the Plasma Block® has much more ozone output than the application requires. You would know this if, for example, if the closed loop control from an ORP unit always had the PDM adjusted to a very low value of current, like 6-10ma.

OR

A PlasmaBlock® is going to be applied at pressure and flow range that is different from the factory setup.

REMOVE POWER FROM THE INVERTER FOR SET UP

1. **Install a true RMS current clamp-on meter** to one of the mains AC power wires, terminals 1 or 2 of Connector 2. A power meter could also be used.
Note: An inexpensive and surprisingly accurate power meter can be purchased for \$25-\$35: UPM model EM100 or Kill-A-Watt from P3 International.
2. **PDM should be set at 100%**. Another method of turning the PDM to full ON if it is more convenient is to turn **Switch S1 OFF**. This forces the PDM at 100%.
3. **Verify Switch S4 and S5 OFF**: fault enable. This will prevent any faults, current exceeding the High/Low limits for example, from shutting down the unit while it's being adjusted.
Note: **Maximum power safety is now OFF. It is possible to damage the ozone cell.**
4. **Pull jumper J5 AUTO**, which will select the **Semi-Auto** mode and allow the **VOLTAGE** pot (potentiometer) to be manual active. The frequency will still be automatically adjusted for resonance.
5. **Turn the VOLTAGE pot counterclockwise (CCW)** until clicking sound indicates minimum.

APPLY POWER TO THE INVERTER – TURN THE INVERTER ON

6. **Adjust the VOLTAGE pot CW** to the desired maximum current (power) level permissible. Ozone levels alone can also be used to establish maximum power if satisfactory at a lower current (power). The processor continues to optimize other aspects of the tuning process as indicated by the occasional 'wink' of the **LOCKED** (resonant frequency found) LED. If the **VOLTAGE** control is increased excessively (pot CW), and a safety limit is reached, the pair of Red LEDs will **flash rapidly** in an alternating manor. This will not damage the ozone cell. Simply **reduce** (CCW) the voltage **control** to an acceptable level of current (power) and the LEDs will extinguish.
7. **Set the High/Low power limits.**
Push the **OP_OK** push switch once (1 to 5 seconds). Two Yellow LEDs will come on and blink slowly. This is the +/- 40% power fault tolerance limits.
Push **OP_OK** once again. The Yellow LEDs will flash faster. This is the +/- 20% limit.
Push **OP_OK** once again. The Yellow LED will flash even faster. This is the +/- 10% limit.
Keep pushing **OP_OK** and the cycle repeats.
The normal factory recommended limit is +/- 20% (40% total).
8. Lock in the new operating point by **pushing and hold the 'Op_OK' button until the Red LEDs come ON**. Then release it. Then ALL the LEDs will come ON (except FAULT) momentarily to acknowledge your input and the inverter will turn OFF. This action permanently stores the new parameters in the processors memory and causes a reboot of the unit.
9. Set Switches **S1, S4** and **S5** to ON. Reinstall **J5 (AUTO_TUNE)**. Re-enable by cycling the inverter OFF and ON.
10. Now observe the inverter gradually increase power to the new programmed level automatically at 100% PDM. Frequency control is automatic and the **LOCKED** LED will cycle indicating frequency lock. The inverter PDM can now control power from 1% to the 100% new programmed value.

You should now observe that the PDM level (power control) being commanded from the ORP unit is much greater, for example, hence making the control loop more stable.

OR

The inverter is now properly configured for new pressure or flow ranges.

Section 6 Shutdown Procedure

- (1) Shut off ozone
- (2) Continue oxygen flow
- (3) Shut off AC input to unit
- (4) Shut off oxygen flow
- (5) Shut off water cooling if being used
- (6) Verify backflow prevention methods are functional

Section 7 Technical Support

Technical support is available by telephone daily (Mon – Fri 8am – 5pm Central Time Zone) at Plasma Technics Inc. 262-637-7180.

Online Support is available 24/7 thru the PTI web site www.plasmatechnics.com (Support Tab / Installation and Operation Manuals AND/OR Training/Instructional Videos). The pdf manuals and videos cover most of the typical customer support questions. The pdf manuals are downloadable.

Section 8 Maintenance and Return Procedure

Product returns for repair/maintenance should have an RMA number clearly displayed on the packaging. Call PTI at the number above to assign a specific RMA number to a return. RMA numbers are assigned to each individual unit being returned. Have the following information ready...

Unit type

Serial number

Model number

Your contact info

Section 9 Specs and Features

- **All high voltage is safely contained completely within the Plasma Blo₃ck© thereby eliminating shock hazards and dirt build up which can cause dangerous flash over. High voltage wiring is booted and all metal grounded. Directly installable by UL 508a panel house.**
- Advanced design eliminates the possibility of ozone leakage from the body or fittings. The only ozone leak possible is at the customer tightened ozone fitting. All non-metal materials are ozone rated.
- **Micro Channel®** design results in high concentration, reduced high voltage levels and more efficient operation. **Requires concentrator or bottle feed of at least -60°F dew point, filtered (.1 microns or less), positive pressure oxygen.** Materials in the gap are: **ceramic and aluminum.**
- Precision machined aluminum block eliminates inefficient hot spots and facilitates operation at **high pressures**, as well as **vacuum ride through**. Only 1 psi drop with 10 LPM. Flow. As with any cell, the most predictable performance occurs in the positive pressure domain.. Maximum pressure 100 psi. 2.7 safety factor at 150 psi.
- Ozone level automatically controlled to ± 1% from 85 to 130vac; or 170v to 260vac depending on model.
- Pre-mounted, seasoned and tested package sub-system, which includes cell, transformer, inverter and fan. Design uses the finest quality material and machining for maximum performance and efficiency.
- Military grade conformal coating eliminates problems associated with condensation and mold as well as greatly retarding damage caused by accidental ozone exposure.
- The inverter is a reduced power version of PTI's popular DAT210. All control and interface features of the DAT210 are available in this product. The 10g, 20g, and 26g units have a DAT310 PCB with similar features.
- **23 kHz** operating frequency for **silent** operation. 240 VAC 3 Phase, 50/60 Hz, 10.7 amps.
- **Inlet 3/8", Outlet 3/8" both Stainless Compression** are standard; 1/4" or 1/4" NPT on request.

Pre-seasoned, calibrated and **pre-adjusted to customer's individual performance needs – ready to install.** Rigorous 100% performance and burn-in tests of all electricals are conducted to insure the highest level of product **quality, reliability and consistency.**

Section 10 Performance Graphs

Ozone Performance Measurement Technique

PTI's flow bench utilizes tank supplied oxygen, delivered through pressure regulators. Our customer's most often use oxygen concentrators and their feedback confirms the notion that ozone production is equal to or better than PTI's published data using pure oxygen. We use bottled oxygen because many customers require products set to pressures in the range of 20 to 100 psi.

Flow is measured at the cell inlet via both Rotameter and mass flow. **Inlet flow devices** are on the oxygen side at **test pressure**, which implies the Rotameter must be corrected to standard LPM for proper sizing of the concentrator. PTI's mass flow meter corrects for 100% oxygen as well as gas pressure and temperature.

All pressure readings are psig and are measured at the distribution manifold outlet and inlet to minimize any pressure drop errors caused by higher flow rates.

Ozone flows from the Plasma Block® under test into the flow bench, and has its flow rate controlled by precision needle valves. From this point on, ozone is essentially at atmospheric pressure. An ozone side stream is encouraged to travel into the analyzer at a rate of about 1 lpm, but is still at atmospheric pressure. A filter is also in-line with the analyzer inlet to prevent any possibility of fouling. All ozone leaves the flow bench at atmospheric pressure.

PTI has chosen the simple Rotameter method of performance presentation in the hope of simplifying the total process. Once a one-time correction is accounted for and the concentrator is sized, the actual running system will agree with PTI's published data, because virtually all installations use simple, inexpensive, air-calibrated Rotameters.

Equipment List:

Power by one of the following: Yokogawa WT110, Magtrol 5100, Fluke 43B, Fluke 41B.

Flow: Key Instruments Rotameters, Mass Flow TSI 4043 (with gas temp and absolute pressure display)

Pressure: mechanical pressure gauges, all \$100+

Ozone: InUsa Mini Hicon (g/nm³), BMT 964.

Compensation equation for PSA concentrator feed gas flow rate:

Actual Standard Liters/Minute \cong Rotameter flow * (Air to Oxygen flow meter coefficient) * $\sqrt{(14.7+\text{psi})/14.7}$

Example: Inlet pressure = **10 psi**; Rotameter flow from test system or performance curves = **12 lpm**

Actual standard Liters/Min \cong 12 * .95 * $\sqrt{(14.7+10)/14.7}$
 \cong 11.4 * $\sqrt{1.68}$
 \cong **14.78 lpm**

Note that temperature correction is generally neglected at typical room temperatures.

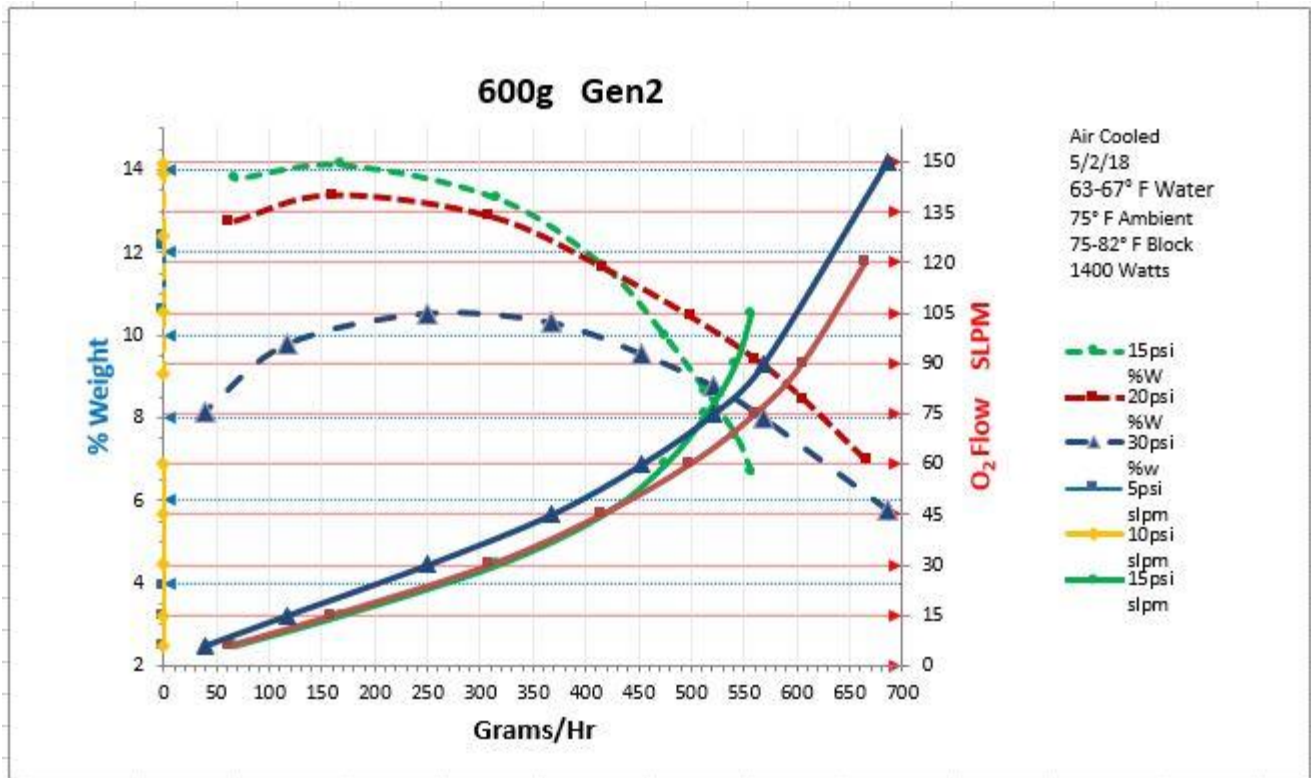

Additional performance charts are shown on the PTI web site www.plasmatechnics.com

Section 11 Product Dimensions: Inches

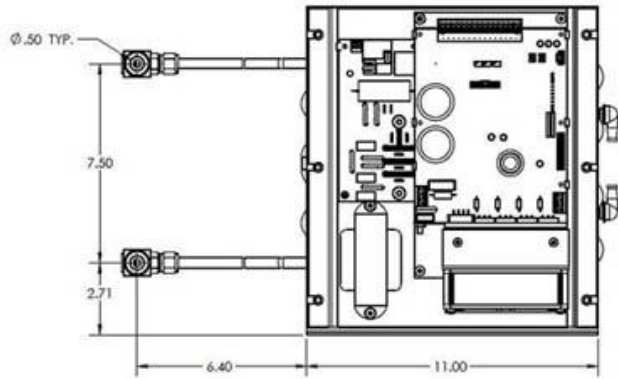

Front View

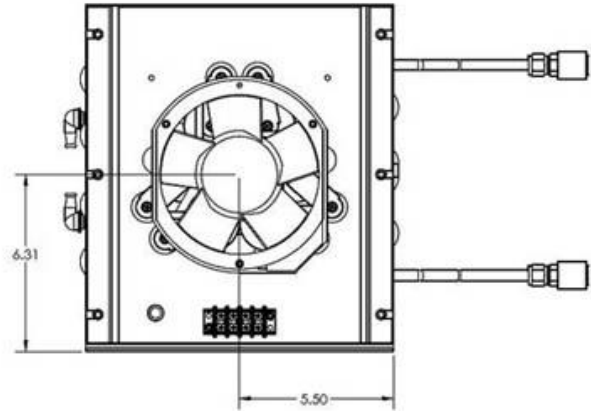

Back View

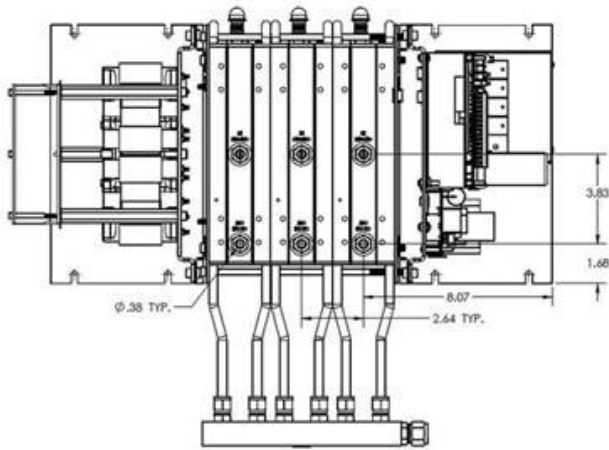

Top View

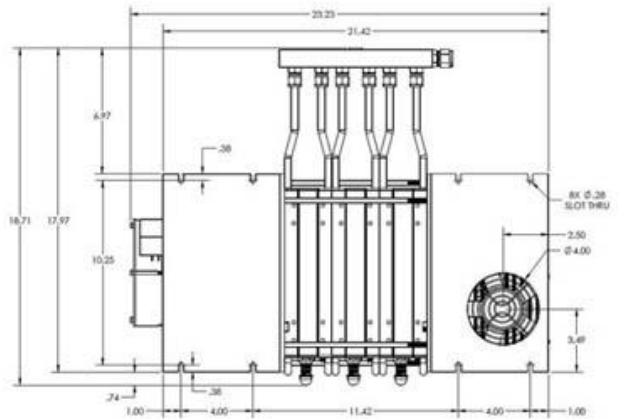

Bottom View

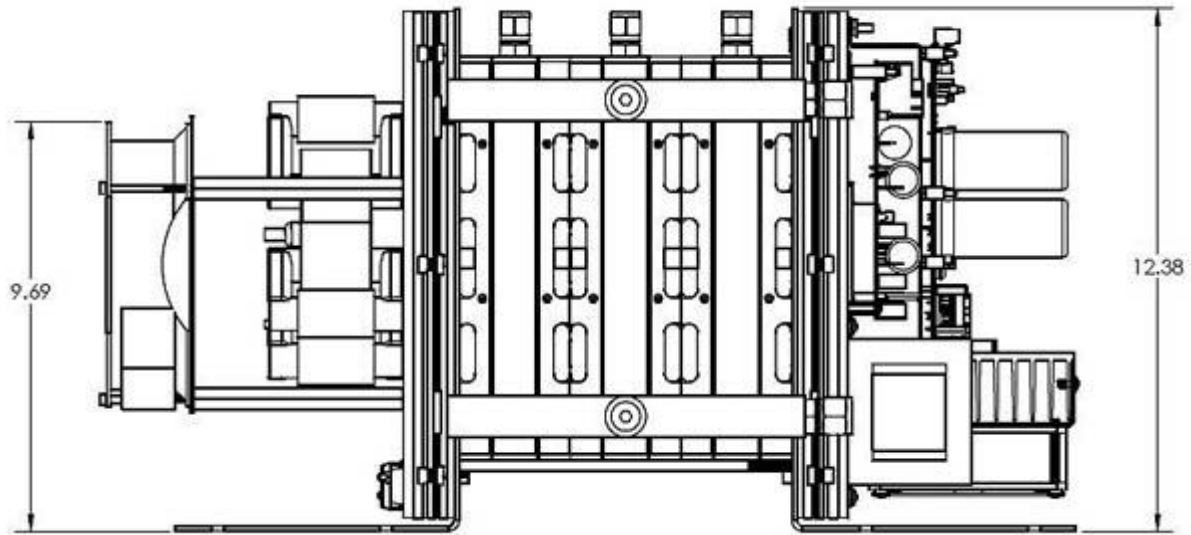

Section 12 Wiring Diagram and Connections

DAT210

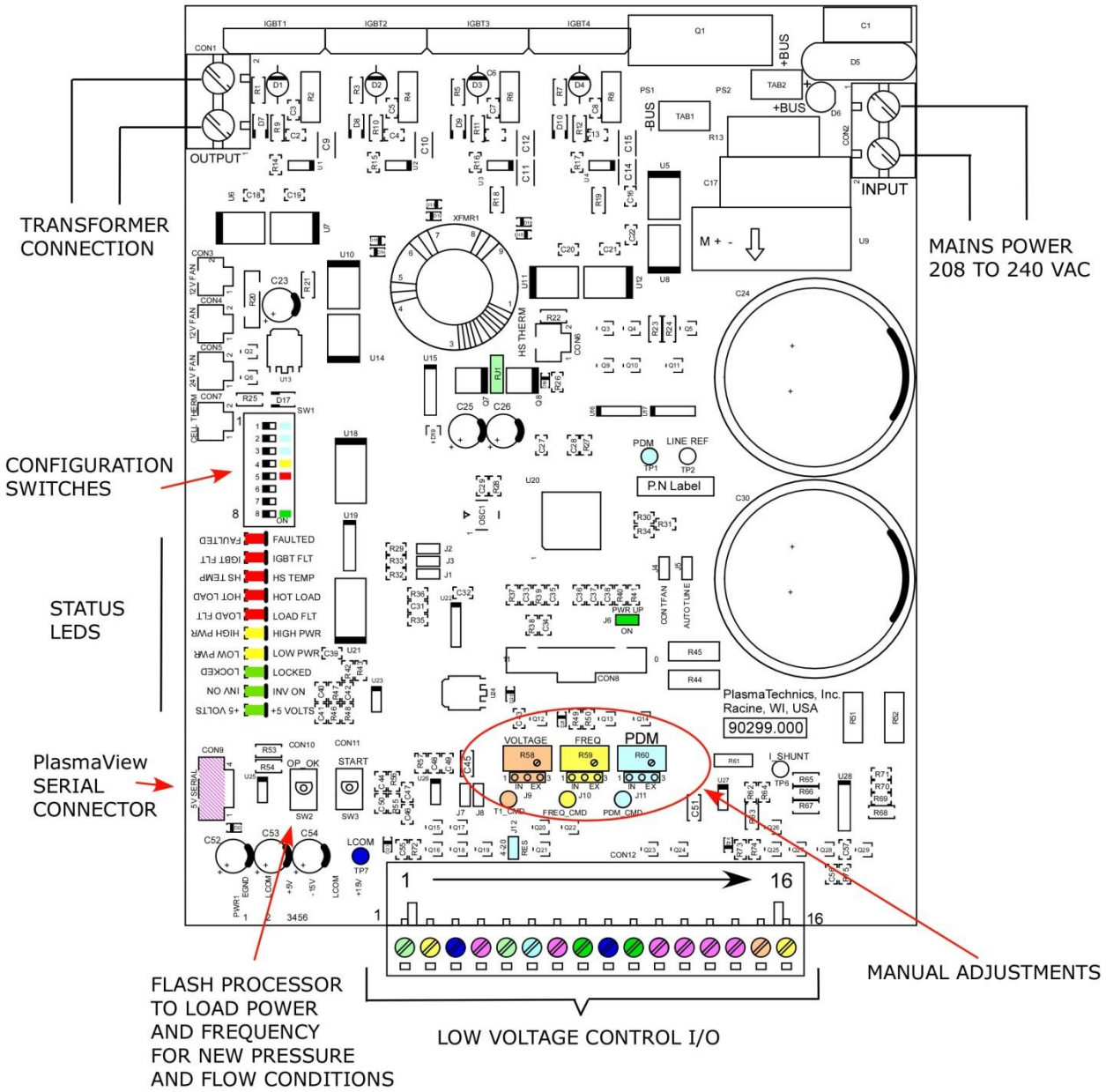

DAT210 Control Connections

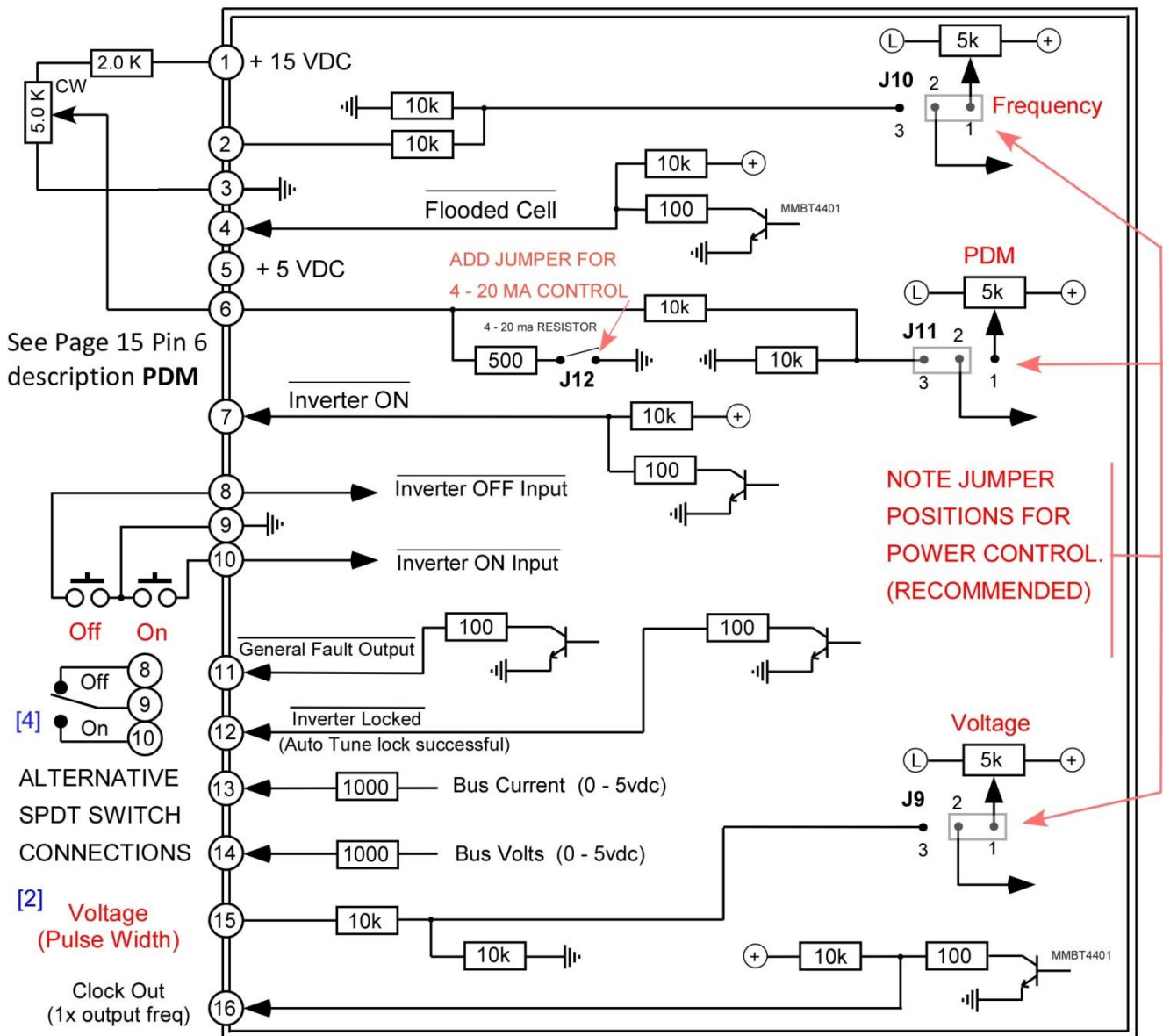

- Grounding either #3 or #9 is not necessary and usually controlled by PLC.
 - External pots for frequency and voltage should be multi-turn, cermet substrate types for stability and precision. Rating of 1/4 watt.
 - Shielded cable recommended for connection runs of 2' or more.
- [1] Optional but recommended (1/4w) to obtain full use of potentiometer range.
- [2] External pot 5k, 2000 ohm resistor recommended as per note 1.
- [3] Ground symbol represents circuit board floating common, not earth grounded. Best to leave floating or allow PLC to establish the ground relationship.
- [4] Optional SPDT toggle switch or relay.

DAT210 Connections

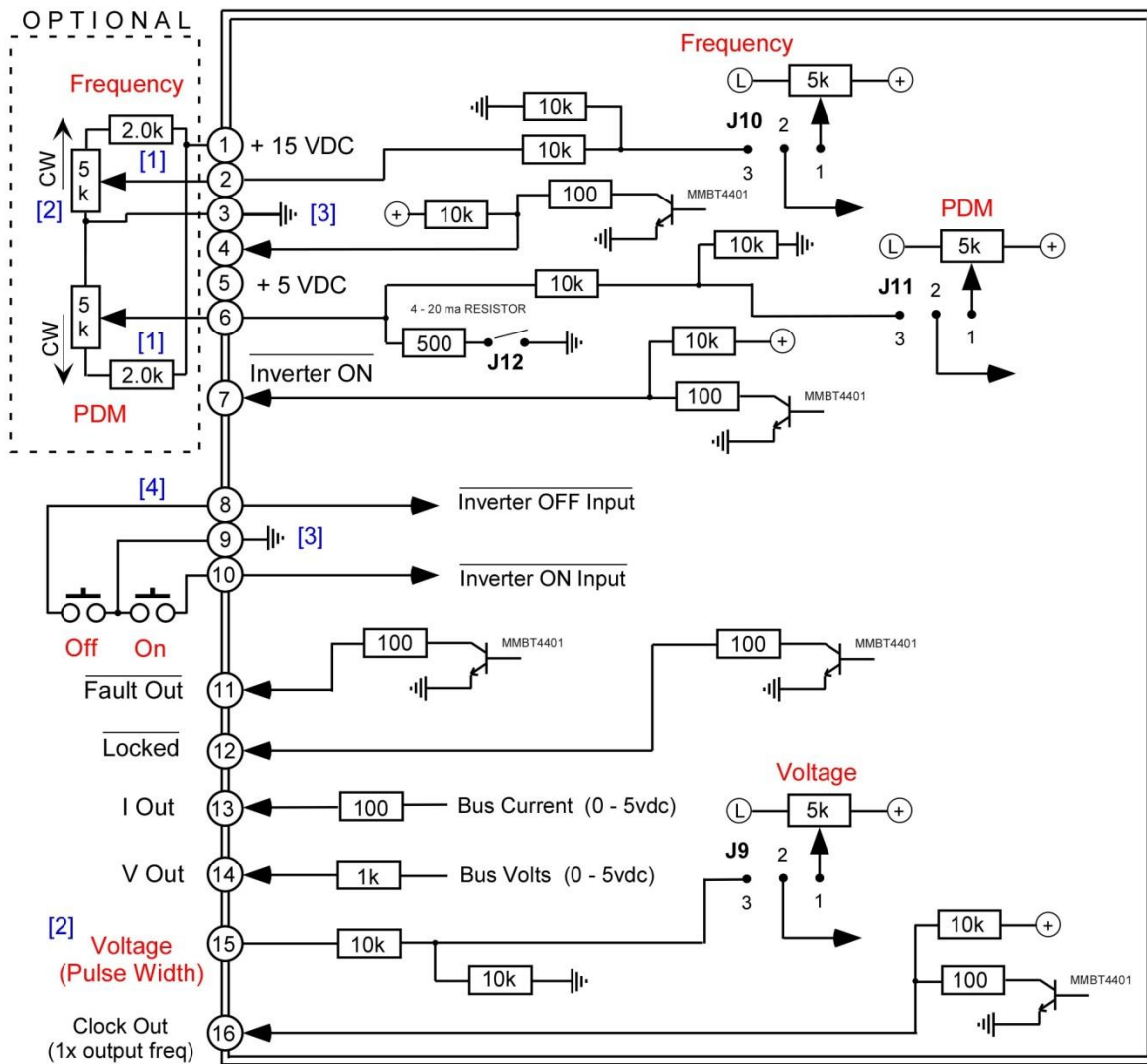

- Grounding either #3 or #9 is not necessary and usually controlled by PLC.
- External pots for frequency and voltage should be multi-turn, cermet substrate types for stability and precision. Rating of 1/4 watt.
- Shielded cable recommended for connection runs of 2' or more.
- [1]** Optional but recommended (1/4w) to obtain full use of potentiometer range.
- [2]** External pot 5k, 2000 ohm resistor recommended as per note 1.
- [3]** Ground symbol represents circuit board floating common, not earth grounded. Best to leave floating or allow PLC to establish the ground relationship.
- [4]** Optional SPDT toggle switch or relay.

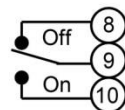

Section 13 Install Options

PlasmaLINK



A **new** way to connect and communicate with your **Plasma Block®**. The PlasmaLINK unit connects to the DAT series board on Plasma Block® units.

Links Available:

Wi-Fi

USB

RS232 via USB

Ethernet

HDMI

Design Features:

- Communicate via Wi-Fi , local LAN or Internet using a PC, laptop or smartphone
- Standard browser navigation screen
- Collect, store and analyze performance data from local or remote locations
- Monitor performance and/or troubleshoot a unit from local or remote locations
- Monitor up to two (2) units at a time
- Mobile device application available for iOS and Android

PlasmaVIEW Software

PlasmaVIEW® software enables unprecedented access to the PlasmaBlock® processor thereby simplifying bench-top setup and field diagnostics. The program displays charts for all measurement parameters with an unlimited time base and disk drive storage for delayed retrieval and emailing. PlasmaVIEW can also be used as a file viewer so data can be studied and expanded at a later time or in another location. Observing a complete functional system over the weekend is as easy as plugging in a laptop computer and spending the weekend with the family.

Testing of the fully integrated ozone system is simplified by the programs ability to create a fault at the output terminals. This enables the user to evaluate the total systems response to the PlasmaBlock outputs without the need to jury-rig external wires thereby creating exactly the same outputs as would normally be produced. Want to see how the system handles a fault – just click on the ‘Faulted’ LED in the ‘Diagnostics’ tab.

Supports all DAT series control boards. Supplied with the software is: PTI’s custom RS232 processor interface adapter, USB/RS232 adapter and 10’ RS232 extension cable.

