

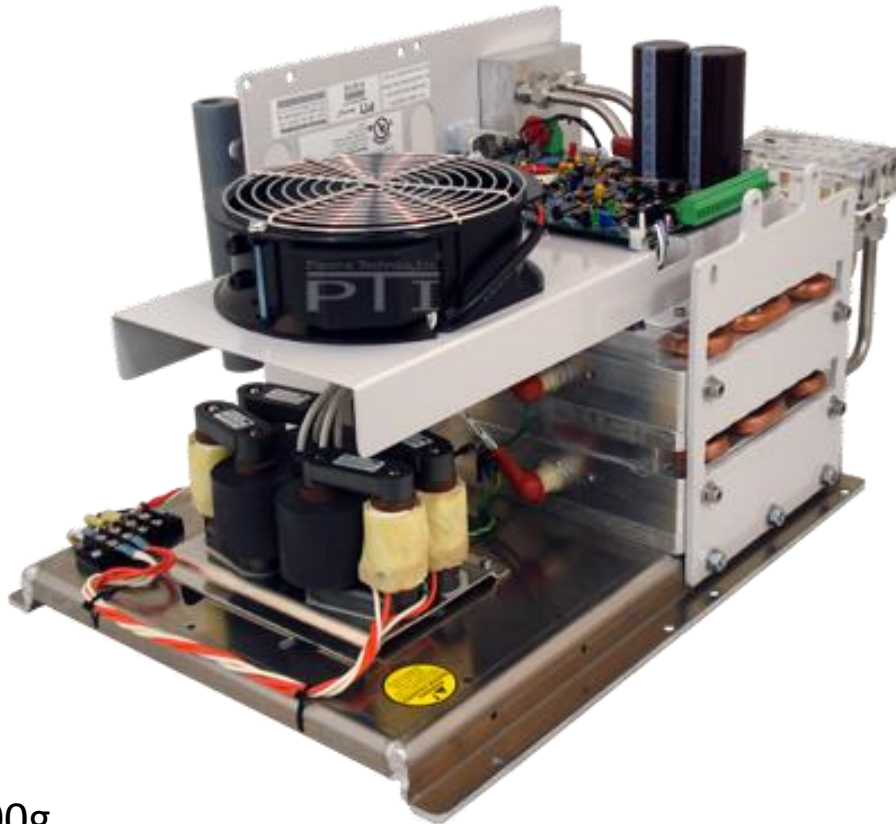

# INSTALLATION & OPERATION MANUAL Plasma Blo<sub>3</sub>ck



PBW 300g

For added application information, see the Plasma Block® Application Guide manual

Appnote PBW-300g V1d  
6/27/13

# TABLE OF CONTENTS

	PAGE
TABLE OF CONTENTS	2
FEATURE LIST	3
<b>INSTALLATION AND OPERATION OF PLASMA BLO<sub>3</sub>CK<sup>®</sup> COMPLETE ASSEMBLIES INVERTER AND CELL</b>	
SECTION 1	GENERAL INSTALLATION MOUNTING REQUIREMENT AND ENVIRONMENT 4
SECTION 2	GENERAL WIRING PRACTICES 5
SECTION 3	GENERAL OPERATING CONSIDERATIONS 6
SECTION 4	CHANGING THE FACTORY CONFIGURATION 8
SECTION 5	PERFORMANCE GRAPHS 10
SECTION 6	MECHANICAL LAYOUT 12
SECTION 7	WARRANTY 13

PLEASE REFER TO THE **DAT 210** OR **SSD 110** MANUALS FOR INVERTER SPECIFIC INSTALLATION AND OPERATIONAL DETAILS.  
REFER TO THE **PLASMA BLOCK<sup>®</sup>** APPLICATION GUIDE FOR INSTALLATION TIPS.

# 300 grams/hr @ 5% Plasma Blo<sub>3</sub>ck™ (Liquid-Cooled)

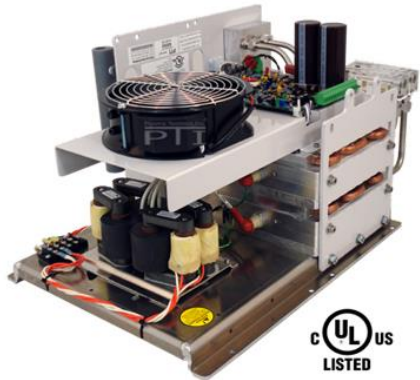

- **Silent, Rugged, Reliable**, Cost-effective, **Compact** and Light Weight, Ceramic, **Liquid-cooled** and power-Efficient.
- **300 g/hr (15.8 PPD) @ 5% wt, 60 LPM and 2400 watts.**  
**91 gr/hr (4.8 PPD) @ 9.2 % wt, 10 LPM and 2000 watts**
- **Precise ozone control using Pulse Density Modulation (PDM)** via potentiometer, 4/20 ma or 0-10 VDC.
- **Precise Control with Turn-down to 1%.**
- **Useful pressure range: 5 – 100 psi.**

## Design Features:

- All high voltage is safely contained completely within the Plasma Blo<sub>3</sub>ck© thereby eliminating shock hazards and dirt build up which can cause dangerous flash over. High voltage wiring is booted and all metal grounded. Directly installable by UL 508a panel house.
- Pre-mounted, seasoned and tested package sub-system, which includes cell, transformer, inverter and fan. Design uses the finest high quality material for maximum performance and efficiency.
- Advanced design eliminates the possibility of ozone leakage from the body or fittings. The only leak possible is at the customer tightened ozone fitting.
- **Micro gap** design results in high concentration, reduced high voltage levels and more efficient operation. **Requires concentrator or bottle feed of at least -60°F dew point, filtered (.1 microns or less), positive pressure oxygen.** Materials in the gap are: **ceramic and aluminum.**
- Precision machined aluminum block eliminates inefficient hot spots and facilitates operation at **pressure, vacuum and atmospheric.** Only 1 psi drop with 20 LPM. Flow. As with any cell, the most predictable performance occurs in the positive pressure domain. Maximum pressure 100 psi. 2.7 safety factor at 150 psi.
- Ozone level automatically controlled to ± 1% 170 v to 260 VAC depending on the model options
- The Inverter is the popular DAT210. All analog control and interface features of the SSD110 are available in this product plus digital serial access to PlasmaView® software.
- **23 kHz** operating frequency for **silent** operation.
- Line voltage 240 VAC 1 phase (standard) 3 phase optional, 50/60hz. The optional line reactor for power factor correction and soft start components are recommended.
- Inlet 3/8", Outlet 3/8" both 316 SS.
- Rigorous 100% performance and burn-in tests of all electrical connections are conducted at elevated operating temperature to insure the highest level of product **quality** and **reliability.**
- Pre-seasoned and performance tested to insure the highest level of product **quality** and **reliability.**
- Military grade conformal coating eliminates problems associated with condensation and mold as well as greatly retarding damage caused by accidental ozone exposure.

# INSTALLATION AND OPERATION OF Plasma BLO<sub>3</sub>CK® COMPLETE ASSEMBLIES INVERTER AND CELL

## Section 1. GENERAL MOUNTING REQUIREMENTS

1. Mount to allow O<sub>2</sub> flow meters to work for user feedback. The assembly contains a cooling fan which cools the transformer. Allow 1.25" to 1.5" clearance between the top of the fan and an enclosure surface.
2. Read the nameplate for operating line voltage and current adjustment levels. **Use copper conductors only.**
3. Apply only the line voltage indicated on the nameplate.
4. Ground the plate assembly to service green utilizing star washer. **See installation drawing on the product drawings for possible grounding locations and High Voltage safety considerations..**
5. It is **important** to at least **verify** that the **system is set to the proper pressure**. If the pressure is below 5 psi **DO NOT** apply power. A vacuum condition in the generator cell will cause it to fail.
6. Since the generator is set up for maximum power under varying conditions of mains voltage and gas pressure or flow, if the mains power specified for this generator varies by more than 10% at full load, the inverter must be readjusted as shown in the DAT210 manual.

### **Mounting Environment**

The block should be mounted in an environment that is **free** from the following:

*Corrosive or volatile vapors*

*Dust and particles*

*Excessive moisture*

*Shock, Excessive vibration*

*Temperature extremes*

The following environmental specifications apply:

Relative humidity: 5 to 90%, non-condensing. Altitude (maximum): 3,310 ft (1,000 m), de-rating for altitude is 1% for every 300 ft (100m) above 3000 ft (1000m).

Mounting can be in **any axis**.

Pressure and flow requirements are the same as all other Plasma Block® products. Connect oxygen feed gas to port labeled INLET. OUTLET should have a flow restriction control

downstream to produce an operating pressure range of 5 to 100 psi. Oxygen feed should be filtered (.1 microns or less). There should be a pressure sensor on the oxygen INLET and ozone OUTLET lines to assure a positive pressure at all times. The Plasma Block unit should NOT be engaged if positive pressure is not present.

Allow 1" (2.5 cm) **MINIMUM** of space around the fan and areas which vent cooling air. 2" (5 cm) is better.

Surrounding air ambient operating temperature: 0° to 40° C (32° to 104° F)

No heat inducing stray fields are to be present within 3 feet (1 M) of the unit. These fields can radiate from large motors or large power supplies in the KW range.

## Section 2

### ***Wiring Standards and Codes***

The installation person is responsible for following the wiring plan produced by the design engineer for the specific application.

All wiring must conform to the following standards:

National Electrical Code, Publication NFPA No. 70.

All local and national codes which apply. For motor usage; use appropriate NEMA relay for protection.

**The supplier cannot assume responsibility for the compliance or noncompliance to any code governing the proper installation of this equipment.**

### ***Electrical Connection Wire Sizing and Fusing***

The DAT210 input current ratings: 300g = 7.2 amps RMS at 240 VAC (5.8 Amps per phase at 240 VAC 3 ph). See graphs for complete power adjustment data. Use branch circuit fuses suitable for use on a circuit capable of delivering not more than 20 A RMS Slo-Blo, 250 volts maximum. Refer to the National Electrical Code[NEC], Publication NFPA No. 70, Article 310, and any local codes that may apply for wire sizing and selection. Use 60/75°C wire min. Use copper conductors only.

Terminal connection max torque .37 inch lbs [0.5 newton meters (Nm)].

### ***Water Cooling Considerations***

Maximum cooling water pressure 71 psi / 498 kpa. Warning: If connection is made to a potable water system, the system shall be protected against backflow. 1-3 gpm [1 typical] is sufficient flow but water temperature is the determining factor.

### ***Case Ground***

Each of the blocks must be connected to ground at their case ground terminal. A grounding electrode conductor or bonding jumper must be connected from the ground terminal to

either a grounding electrode buried in the earth or a suitable plant ground with solid connections to earth ground. Refer to NFPA No. 70, Article 250, for details on grounding and grounding electrodes.

### ***Safety Grounding***

The case ground connections should be made at the ground terminals. The case ground of the various system components should be connected to the star grounding bus of the cabinet. A grounding electrode conductor or bonding jumper must be connected from the star grounding bus to either a grounding electrode buried in the earth or a suitable plant ground with solid connections to earth ground. Refer to NFPA No. 70, Article 250, for details on grounding and grounding electrodes.

**The only external connections for control needed are the ON/OFF switch. Note that an OFF contact closure will shut off the inverter even if the ON contact is made. The OFF contact takes priority.**

**All adjustments can be made on the inverter as shown with the jumper positions shown at the INTERNAL CONTROL position. The VOLTAGE and FREQUENCY are pre-adjusted to your purchase order specifications. Power adjustment is only by the PDM potentiometer for normal operation turndown 0 – 100%. PDM may be changed from 0 – 10 VDC to 4 – 20 ma for output control in your final equipment. See the DAT 210 inverter manual for details.**

240 VAC wiring should be rated 20 Amps.

**There MUST be a green wire earth ground from the chassis to conduit ground. This is an important safety and reliability feature.**

### **Section 3      General Operating Considerations**

1. Special configurations are necessary for 240 VAC mains voltage. If 240 3 phase is used, the DAT213 must be specified. An optional link choke increases the power factor to about 0.9. This reduces peak currents and mains current distortion.
2. When AC power is applied, an inrush will occur - this is normal. A typical system will require a 10-amp circuit breaker. If the inverter line voltage will be turned on frequently the relay or switch should be amply sized to prolong its life due to the high inrush current. A soft charge circuit is recommended in this case and can be found in the DAT210 operator's manual. This will also extend the life of the DAT210.

3. The Plasma Block is built with aluminum and ceramic. While aluminum provides maximum safety for applications like water purification, it does react with nitric acid that would be produced if atmospheric air were to be used rather than a concentrate for gas feed. For this reason **ONLY a concentrator or O<sub>2</sub> can be used to provide the feed gas.** To maintain the warranty the feed gas must be at least -60°F dew point and 93% O<sub>2</sub> or more.
4. **BEFORE** the system is energized for the first time the Plasma Block should pre-dried by flowing the above feed gas for 3 to 5 minutes. If the installed system will be dormant for long intervals then the control system should do a pre-purge to insure the system is dry before power is applied to the cell.
5. When a system is off for an extended period, it is very important to prevent backflow of liquids and gasses through the cell. Backflows void the cell warranty. For example, systems which use a venturi and concentrator must contain a solenoid valve to block gas flow if it is possible that the venturi will be active while the concentrator is off. See the Applications document for more detail and installation suggestions.
6. When the Block requires servicing, return it to the factory - DO NOT disassemble. The Plasma Block is fitted with a tamper label. If the label is broken, the warranty is void.
7. **While it is possible to configure the system to accommodate negative pressures, negative pressures are problematic and tend to cause large power and ozone fluctuations. The most stable and predictable systems occur at positive pressures.**
8. The ozone outlet fitting mounted into the plasma block mates with other fittings inside of the unit and **must not be removed or changed** to another fitting type. Contact the factory if other sizes or styles are required.

### ***Safety Considerations***

#### **DANGEROUS VOLTAGES ARE ON THIS CIRCUIT BOARD**

To avoid injury to personnel and/or damage to equipment only qualified personnel should perform the procedures outlined in this chapter. This person must understand both the electrical and mechanical components associated with the application.

Thoroughly read and understand the following procedures before beginning the start-up process.

The following specific safety procedures must be observed when performing any maintenance or adjustments on the amplifier.

Always turn off and lock out AC power at the main machine disconnects switch. Do this before touching any electrical or mechanical components.

High voltage may be present even with all electrical power supplies disconnected.

Use an appropriate meter to verify that all DC bus capacitor banks have been discharged before working on any equipment. Do not rely exclusively on high voltage RED LED indicator for bus voltage, as dangerous voltage levels may remain even when the indicator is off.



Follow industry recognized safety procedures. Use only one hand to hold test equipment probes, wear approved eye protection, etc. Before energizing the inverter, make sure that device(s) connected to the output of the inverter will not result in injury or damage to equipment. Keep unnecessary personnel out of the immediate work area. Never leave an inverter cabinet open and unattended.

### ***Start-up Checklist***

To ensure a complete checkout and test, check off each step as it is completed. If the proper event does not occur while performing this start-up procedure, do not continue. Take the appropriate action to correct the malfunction before proceeding.

- Ensure the main disconnect switch is locked off. High voltage may be present even with all electrical power supplies are disconnected. Use an appropriate meter to verify that all DC bus capacitor banks have been discharged before working on any equipment. Do not rely exclusively on RED LED indicator of bus voltage, as dangerous voltage levels may remain even when indicator is off.
- Verify that the inverter mounting has been performed in accordance with the guidelines listed in Section 1.
- Inspect the inverter to verify that all optional modules have been selected and installed according to the system drawings and documentation.
- Verify that all wiring has been installed according to the wiring plan produced by the design engineer and according to the guidelines listed in Section 2 for proper connection, grounding, wire size, labeling, routing and applicable codes. The DAT210 does not have internal fusing. Install input and output (optional) fusing per suggestions in the DAT210 manual (Section 7).
- Verify that all electrical terminals, screws, nuts, and bolts are securely fastened.
- Apply high voltage DC or single-phase AC power to the inverter as specified.
- Check to make sure that the RED Bus voltage LED is on, indicating bus voltage.

## **Section 4 Changing the factory power configuration**

### **START-UP PROCEDURE POWER ADJUSTMENT**

Reasons for changing the factory setup:

By altering the 'Voltage' setting, you can easily modify the full power operational point if need be. Remember that the purpose of the PDM control is to provide a turndown from the 100% power set-point established by the **VOLTAGE** pot. The goals are 1) Maximum power and 2) Current High/Low limits. Adjustment is very easy.

If it is determined that the Plasma Block has much more ozone output than the application requires. You would know this if, for example, if the closed loop control from an ORP unit always had the PDM adjusted to a very low value of current, like 6-10ma.

OR

A PlasmaBlock is going to be applied at pressure and flow range that is different from the factory setup.



### REMOVE POWER FROM THE INVERTER FOR SET UP

1. **Install a true RMS current clamp-on meter** to one of the mains AC power wires, terminals 1 or 2 of Connector 2. A power meter could also be used.  
Note: An inexpensive and surprisingly accurate power meter can be purchased for \$25-\$35: UPM model EM100 or Kill-A-Watt from P3 International.
2. **PDM should be set at 100%**. Another method of turning the PDM to full ON if it is more convenient is to turn **Switch S1 OFF**. This forces the PDM at 100%.
3. **Verify Switch S4 and S5 OFF**: fault enable. This will prevent any faults, current exceeding the High/Low limits for example, from shutting down the unit while it's being adjusted.  
Note: **Maximum power safety is now OFF. It is possible to damage the ozone cell.**
4. **Pull jumper J5 AUTO**, which will select the **Semi-Auto** mode and allow the **VOLTAGE** pot (potentiometer) to be manual active. The frequency will still be automatically adjusted for resonance.
5. **Turn the VOLTAGE pot counterclockwise (CCW)** until clicking sound indicates minimum.

### APPLY POWER TO THE INVERTER – TURN THE INVERTER ON

6. **Adjust the VOLTAGE pot CW** to the desired maximum current (power) level permissible. Ozone levels alone can also be used to establish maximum power if satisfactory at a lower current (power). The processor continues to optimize other aspects of the tuning process as indicated by the occasional 'wink' of the **LOCKED** (resonant frequency found) LED. If the **VOLTAGE** control is increased excessively (pot CW), and a safety limit is reached, the pair of Red LEDs will **flash rapidly** in an alternating manor. This will not damage the ozone cell. Simply **reduce** (CCW) the voltage **control** to an acceptable level of current (power) and the LEDs will extinguish.
7. **Set the High/Low power limits.**  
Push the **OP\_OK** push switch once (1 to 5 seconds). Two Yellow LEDs will come on and blink slowly. This is the +/- 40% power fault tolerance limits.  
Push **OP\_OK** once again. The Yellow LEDs will flash faster. This is the +/- 20% limit.  
Push **OP\_OK** once again. The Yellow LED will flash even faster. This is the +/- 10% limit.  
Keep pushing **OP\_OK** and the cycle repeats.  
The normal factory recommended limit is +/- 20% (40% total).
8. Lock in the new operating point by **pushing and hold the 'Op\_OK' button until the Red LEDs come ON**. Then release it. Then ALL the LEDs will come ON (except FAULT) momentarily to acknowledge your input and the inverter will turn OFF. This action permanently stores the new parameters in the processors memory and causes a reboot of the unit.
9. Set Switches **S1, S4** and **S5** to ON. Reinstall **J5** (AUTO\_Tune). Re-enable by cycling the inverter OFF and ON.
10. Now observe the inverter gradually increase power to the new programmed level automatically at 100% PDM. Frequency control is automatic and the **LOCKED** LED will cycle indicating frequency lock. The inverter PDM can now control power from 1% to the 100% new programmed value.

You should now observe that the PDM level (power control) being commanded from the ORP unit is much greater, for example, hence making the control loop more stable.

OR

The inverter is now properly configured for new pressure or flow ranges.

**Section 5 Performance Graphs**

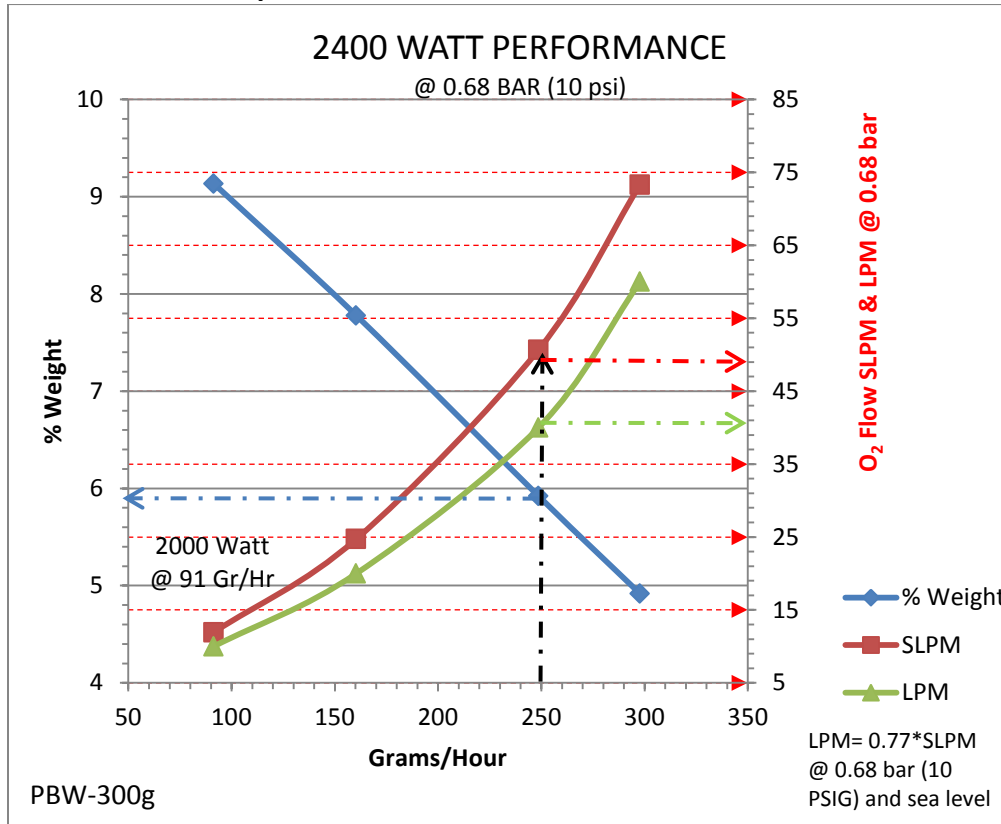

**Normal factory POWER set point: 2400 watts at FULL PDM ( 10vdc or 20ma ).**

Published production-ozone output level (300 gr/hr) based on 5% concentration.

Tests conducted at 22C (72°F), 700' (213 M) MSL: Ozone in g/nm<sup>3</sup>.

Flow measured in LPM via **uncorrected** Rotameter at inlet port. Ozone at 0 psi from side stream.

Fan and power supply burden of 17 watts is included in above chart.

Procedure 1, Grams per hour desired at maximum power:

1. Determine the Grams/hr desired for the chemical reaction. 250 gram/hr for this example.
2. Moving vertically from the value on the horizontal scale at 250 gr/hr, note the % weight (Blue line) on the left axis at 5.9% wt for 2400 watts power at 250 gr/Hr.
3. At the same Grams/hr value move vertically and note both the SLPM at 49 SLPM (red) and indicated LPM (green) at about 41 LPM at the recommended pressure [0.68 bar (10 psi)] on the right vertical axis.
4. If a higher % weight is desired at 250 gr/hr, specify the next larger generator. A generator can always be run at less than maximum power.

Procedure 2 example, Oxygen flow of 15 LPM maximum at 0.68 bar (10 psi) on a rotameter. What is the maximum gr/hr production?

1. Start on the left vertical scale at 15 LPM rotameter reading. Move horizontally to intercept the green LPM line at 15 LPM.
2. Drop down vertically to see what gr/hr is available. It is 130 gr/Hr in this case.
3. Move vertically to intercept the red SLPM line at 18 SLPM and the blue % wt line at 8.5 % wt. Refer to other graphs for additional detail.

Section 5 Performance Graphs

% Weight vs Power

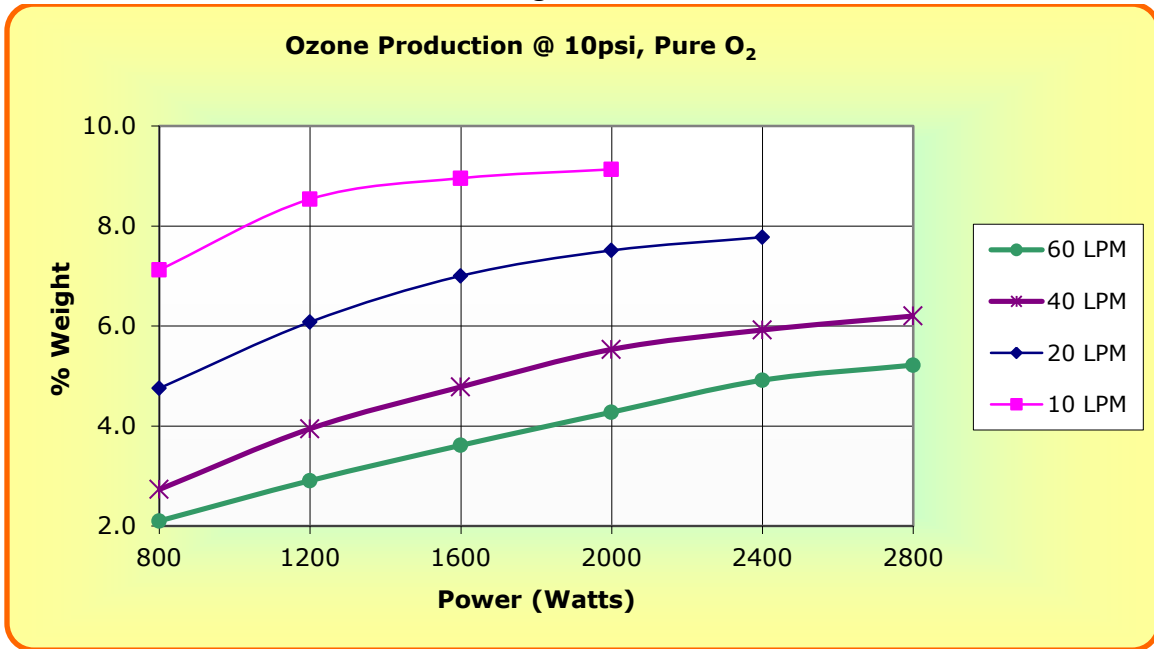

Grams/Hour vs Power

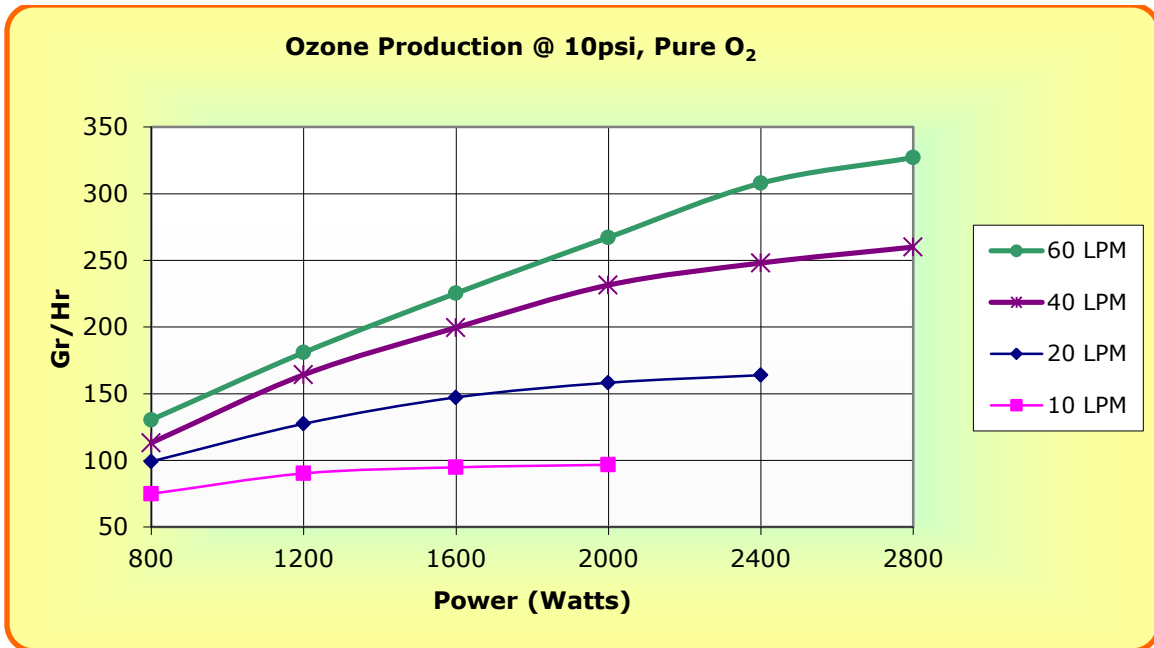

**Normal factory POWER set-point: 2400 watts at FULL PDM ( 10vdc or 20ma ).**  
 Published production ozone output level (300 gr/hr) based on 5% concentration.  
 Tests conducted at 72°F, 700' MSL, Gas: 'Standard' In , 'Normal' Out.  
 Best performance between 10 and 15 psi.

**Section 6**  
**Installation Drawing: Inches: 300g unit**

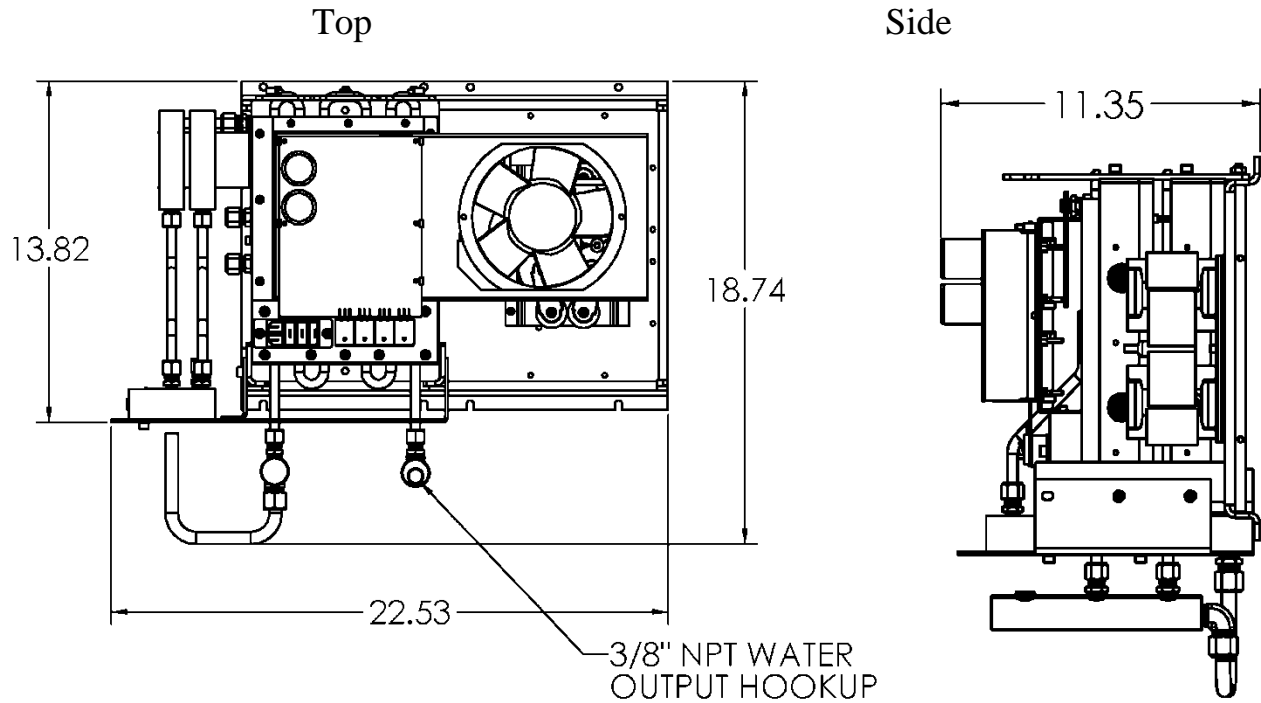

**Front**

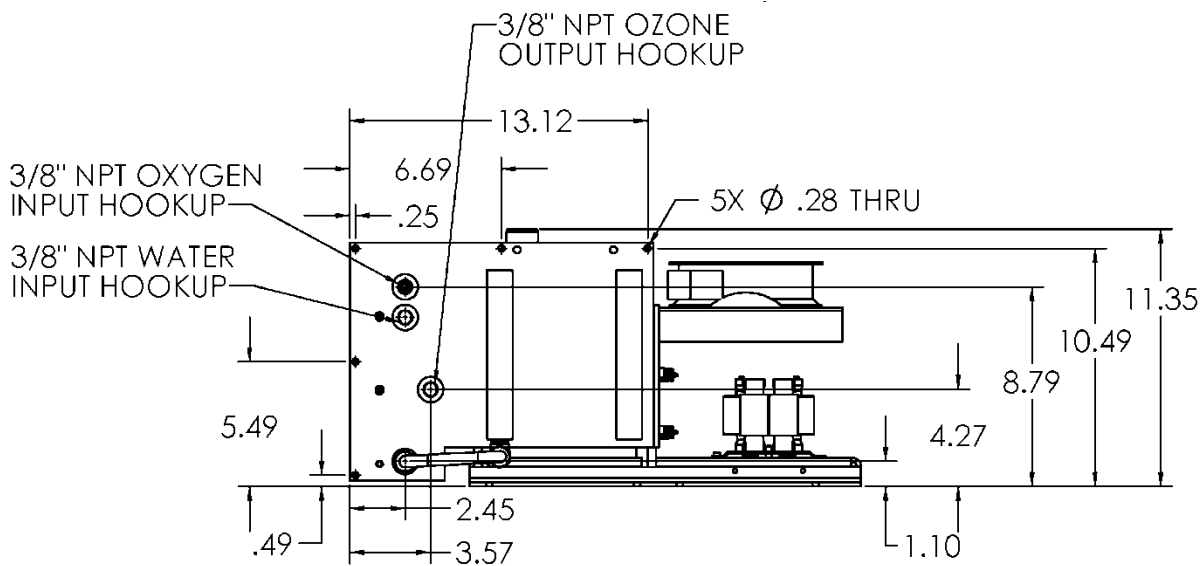

**Section 7**      **Warranty**

## **PTI Plasma Block® Limited Warranty**

The PTI Plasma Block® unit is warranted by Plasma Technics®, Inc., to the original purchaser to be free from defects in material and workmanship under normal use and service for a period of **FOUR (4) years** from the date of purchase under the following terms and conditions:

The obligation of Plasma Technics®, Inc. is expressly limited to repairing or replacing, at the option of Plasma Technics®, Inc., any PTI Plasma Block® returned to it during the warranty period, which is determined by PTI to be defective in material or workmanship.

Any improper use /operation or installation other than in accordance with the published application materials, instructions and specifications established by Plasma Technics®, Inc. shall void this warranty.

The obligation of Plasma Technics®, Inc. Shall not include any transportation charges, costs of removal or installation, labor charges or any direct, indirect, consequential or delay damages.

Attachment or use of components or accessories not compatible with the PTI Plasma Block® shall void this warranty.

Any alteration not authorized by Plasma Technics®, Inc. in writing, accident, misuse, abuse or damage to the PTI Plasma Block® shall void this warranty.

The Plasma Block® subject to this warranty is not warranted as suitable for any particular purpose or use of the purchaser. The suitability of any PTI Plasma Block® for any purpose particular to the purchaser is for the purchaser in the purchaser's sole judgment, to determine. Plasma Technics®, Inc. assumes no responsibility for the selection or furnishing of a Plasma Block® suitable to the purchaser's needs or the purposes of any particular purchaser.

**This warranty is in lieu of any other warranty express or implied, including specifically but without limitation warranties of merchantability or efficacy and of all other obligations or liabilities in connection with the sale or use of the PTI Plasma Block®.**