



QUICK START CHECKLIST & INSTALLATION

Plasma Blo₃ck®

30g



Document: V1a Firmware: 10008.004

MOUNTING

- Make sure there is adequate air flow space around the generator. Allow at least 4 cm (1.5") around the generator on all sides except the mounting side.**
- Make sure the ambient temperature does not exceed 0° to 40° C (32° to 104° F). However, the lower the ambient temperature, the higher the ozone production for at a power setting. Also the reliability of the oxygen concentrator will be better at a lower temperature.**

ELECTRICAL

- Mains voltage should be 100 to 250 VAC 50/60 Hz. A higher voltage above 265 VAC will destroy the power supply.**
- Fusing for the mains voltage is 10 Amps Slo-Blo maximum.**
- Current consumption is 1.1 Amps for the 10g and 2.1 Amps for the 20g generator.**

GAS FLOW

- Feed gas pressure no less than 0.3 bar (5 psi) under all conditions. Don't let the inlet gas shut off valve allow a vacuum from the injector plus application of generator power will damage the ozone cell.**
- Is the oxygen concentrator output at least 93% O₂? Some service calls are caused by a concentrator problem.**
- Does the expected oxygen pressure and flow rate match the purchase order detail? Optimal factory settings are pre-calibrated for the expected pressure and gas flow. If the application is different, follow the detailed instruction manual for tuning.**
- Gas flow is 2 LPM at 5% and 0.3 bar (5 psi) for the 10g generator. 4 LPM at 5% and 0.3 bar (5 psi) for the 20g generator.**
- Check the Inlet and Outlet gas connections. Use TFE tubing for the ozone gas outlet connection. Other plastic tubing will become brittle over time.**
- Add a filter to the gas inlet to prevent oxygen concentrator resin from entering the ozone cell.**
- Use backflow prevention as shown in the diagrams to make sure the process fluid does not enter the ozone cell.**

CONTROLS

- Make sure the J12 jumper in the inverter board is installed for 4 – 20 ma control input. Remove the jumper for 0 – 10 volt control input. See the low power connection diagram.**
- Check the ON – OFF control connections per the diagram. The circuit senses a contact closure transition. Loss of power will require a restart unless configured otherwise with J101. See the detailed instruction manual if there is a control question.**

Installation

- NOTES;
1. ALLOW TIME FOR PSH TO REACT BEFORE TURNING OFF SV.
 2. NEVER ALLOW P1 PUMP TO OPERATE UNLESS PSH IS ABOVE 0.3 BAR (5 PSI).
 3. A BALL VALVE 316SS W/TFE SEALS COULD BE USED IN PLACE OF THE CHECK VALVE.
 4. TUBING CARRYING OZONE GAS SHOULD BE 316SS OR TFE.
 5. FLOW METER BEFORE GENERATOR SHOULD NOT HAVE INTEGRAL NEEDLE VALVE.

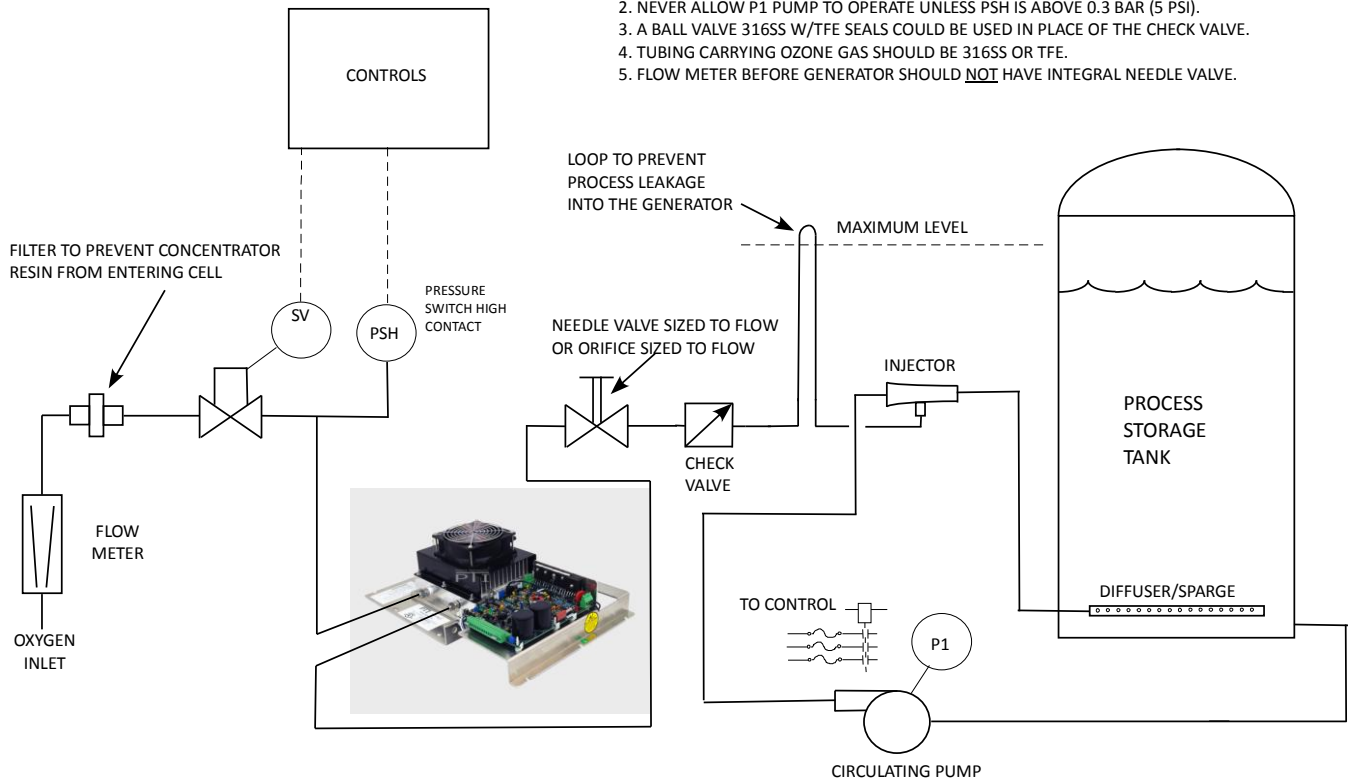

SUGGESTED INSTALLATION

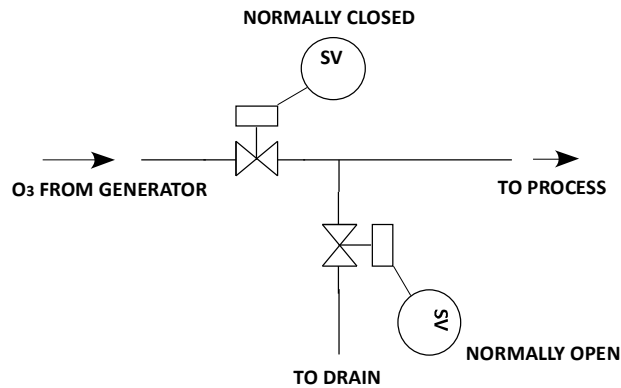

ALTERNATE METHOD OF BACK FLOW PREVENTION

DAT210

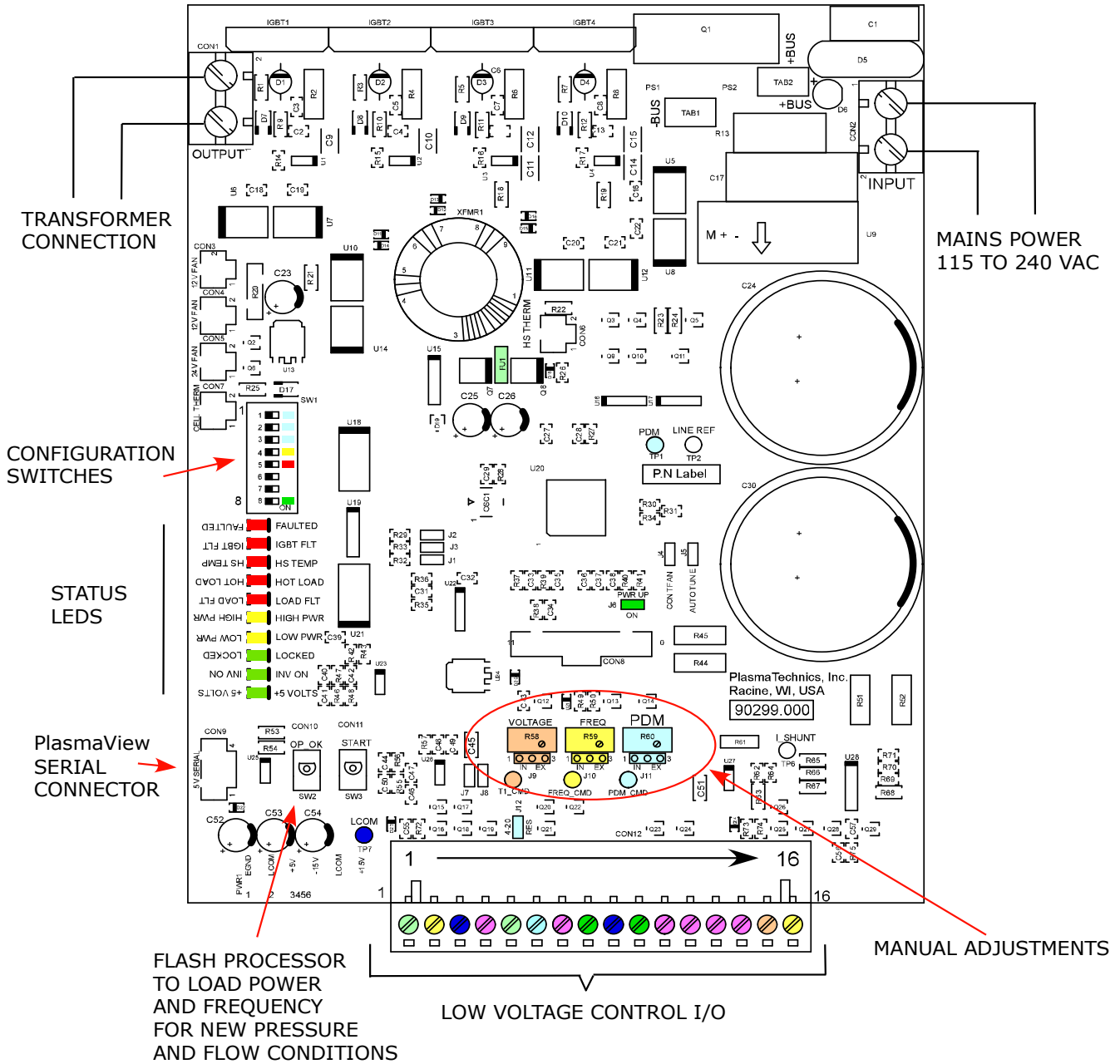

115 VAC wiring should be rated 10 Amps.

There MUST be a green wire earth ground from the chassis to conduit ground. This is an important safety and reliability feature.

The mains can be from 115 or 240 VAC mains. The correct mains is specified on the product label.

DAT210 Connections

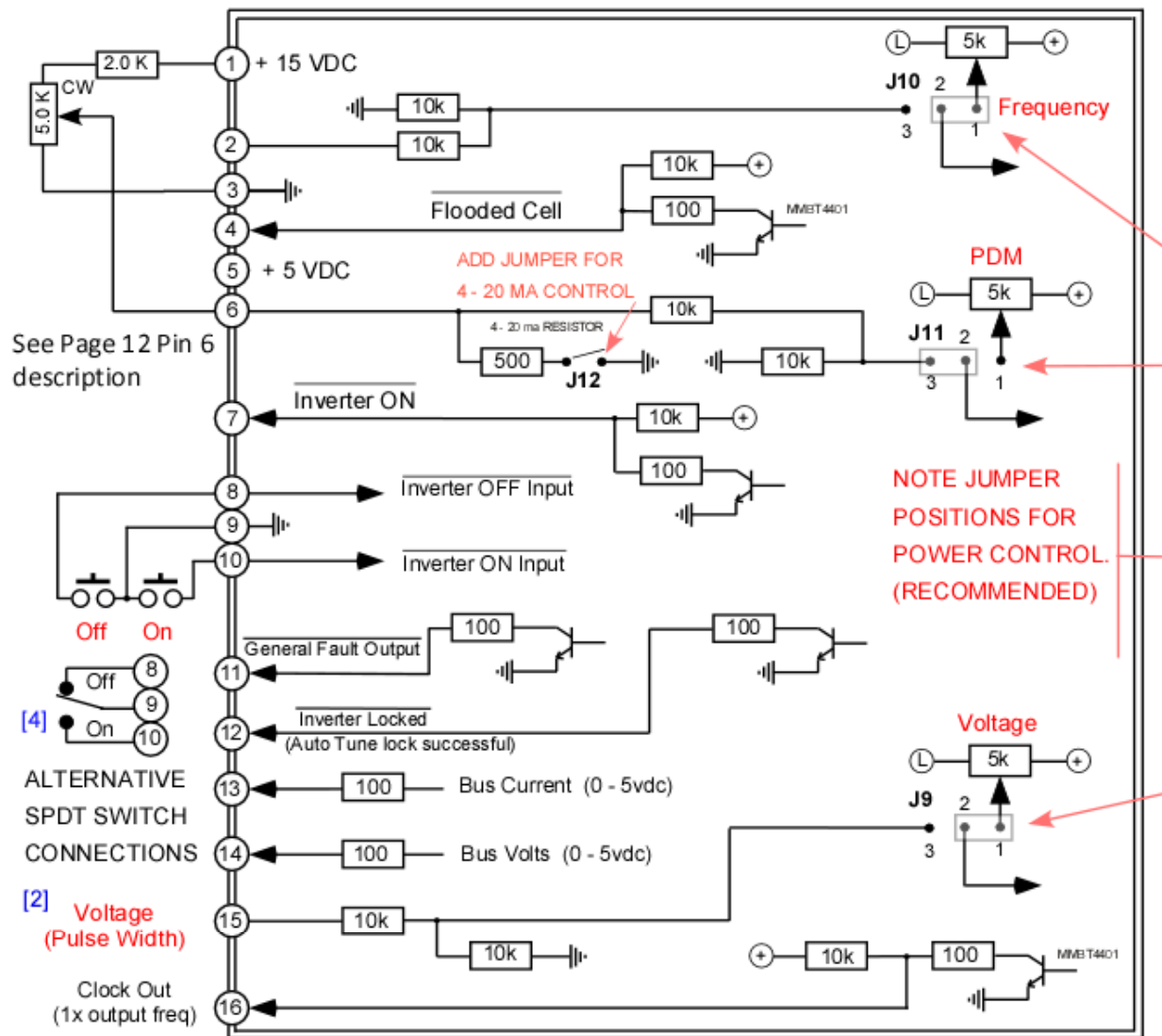

- Grounding either #3 or #9 is not necessary and usually controlled by PLC.
- External pots for frequency and voltage should be multi-turn, cermet substrate types for stability and precision. Rating of 1/4 watt.
- Shielded cable recommended for connection runs of 2' or more.
- [1] Optional but recommended (1/4w) to obtain full use of potentiometer range.
- [2] External pot 5k, 2000 ohm resistor recommended as per note 1.
- [3] Ground symbol represents circuit board floating common, not earth grounded. Best to leave floating or allow PLC to establish the ground relationship.
- [4] Optional SPDT toggle switch or relay.

Jumper block configuration

DAT 210 JUMPER CHART

SWITCH			
SW1	SWITCH POSITION	NAME	FUNCTION IF INSTALLED
S1	ON	PDM Enable	If PDM is remotely commanded, remove to test 100% output level. This is especially useful if the unit is hard wired to a PLC or ORP controller.
S2	OFF	LOW PDM	Lower PDM period than 30 Hz
S3	OFF		Not implemented
S4	ON	HIGH/LOW current fault	A window of normal operating current. This will cause a fault if either the LOW or HIGH value is exceeded.
S5	OFF	Soft fault	Produces a wink in fault line #11 if one or more operational windows are exceeded beyond the factory limit. Will not shut down the inverter like a hard fault but attention is needed. The fault is being managed by the inverter processor.
S6	OFF		Spare
S7	OFF		Spare
S8	OFF	4/20 ma.	Configuration for 4 - 20 ma. control 0 - 100% ozone output. At 2 ma the INV_ON LED will flash. At 3 ma. The output is reinabled. If the jumper is removed, 0 - 10 (0 - 100%) volts controls the ozone output. If the command is for zero ozone, the inverter will be in standby.

JUMPER	INSTALLED	DEFAULT	
J101	OUT	ON with power up	ON-OFF command change. The inverter will turn ON 5 seconds after power is applied and turned OFF when power is removed. This is not recommended because it eliminates gas purge.
J1, 2 & 3		Factory use	
J4	OUT	Manual fan	Fan goes on when power is applied and off when removed.
J5	IN	Full AUTO-TUNE	Voltage and frequency pots are not active. These parameters are controlled automatically. In SEMI-AUTO mode, the voltage pot controls total power but frequency control is automatic.
J9	IN	Voltage control pot	1 - 2 jumper = internal control. 2 - 3 = external
J10	IN	Frequency control pot	1 - 2 jumper = internal control. 2 - 3 = external
J11	IN	PDM control pot	1 - 2 jumper = internal control. 2 - 3 = external
J12	Stored on one pin	Installed = 4/20 ma. Or 0/20 ma. OUT = 0 - 10 VDC	Adds 500 ohm resistor to control input. If two or more DAT 310s are to be controlled via one current loop, wire all Connector CON12 term. 3 together and all term. 6 together and install J12 on <u>one</u> DAT 310 inverter. Usually S8 ON and J12 jumper are used together.

NOTES:

1. Earlier models use the DAT 300 inverter. A cross reference is at the rear of the manual.
2. Jumpers that are configured by the order to be removed will be placed on one pin.

METHODS OF ON – OFF CONTROL

JUMPER BLOCK CONFIGURATION AND FUNCTION

SPDT RELAY OR SWITCH

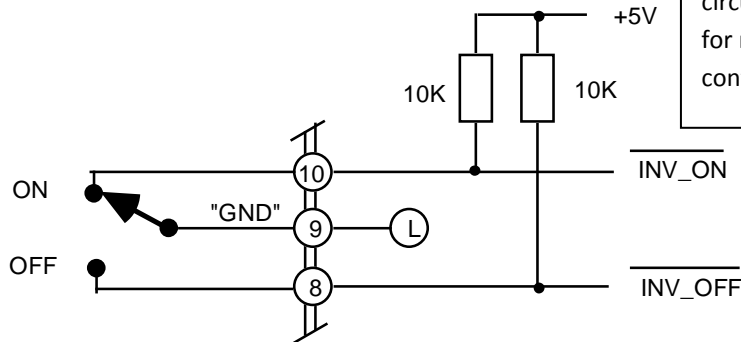

Loss of power when ON: Must turn OFF for 0.2 seconds, then ON. All circuits require AC power OFF & ON for microcontroller to observe new configuration.

FUNCTION	PWR_UP	J1	J2	J3
To start the inverter the switch must first be in the OFF position, then moved to the ON position for ozone to start.	OMIT	OMIT	X	X
To start the inverter the switch or jumper wire must first be across 9 and 10 position, then power is applied to produce ozone. The inverter will start after the "LED banner flash". If 8,9,& 10 are open with this jumper in, the inverter cannot start until the power is removed and 9 and 10 connected.	IN	OMIT	X	X
X = Don't care condition.				

ON – OFF PUSHBUTTONS

Loss of power when ON: Must turn OFF for 0.2 seconds, then ON.

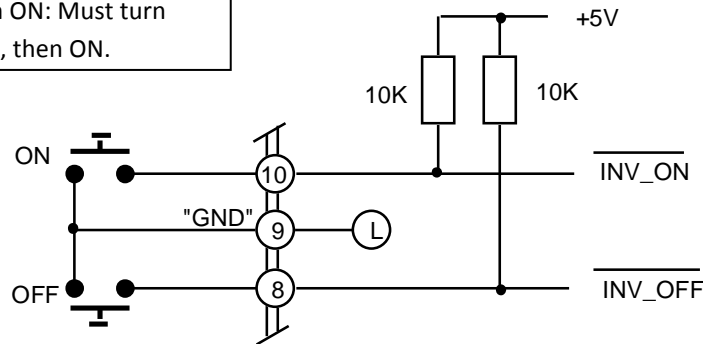

JUMPER BLOCK CONFIGURATION AND FUNCTION

FUNCTION	PWR_UP	J1	J2	J3
Push ON and push OFF to start and stop ozone production. If both pushbuttons are actuated simultaneously, the inverter will stay OFF.	X	OMIT	X	X
X = Don't care condition.				

SAFETY SWITCH INVERTER CONTROL CIRCUITS

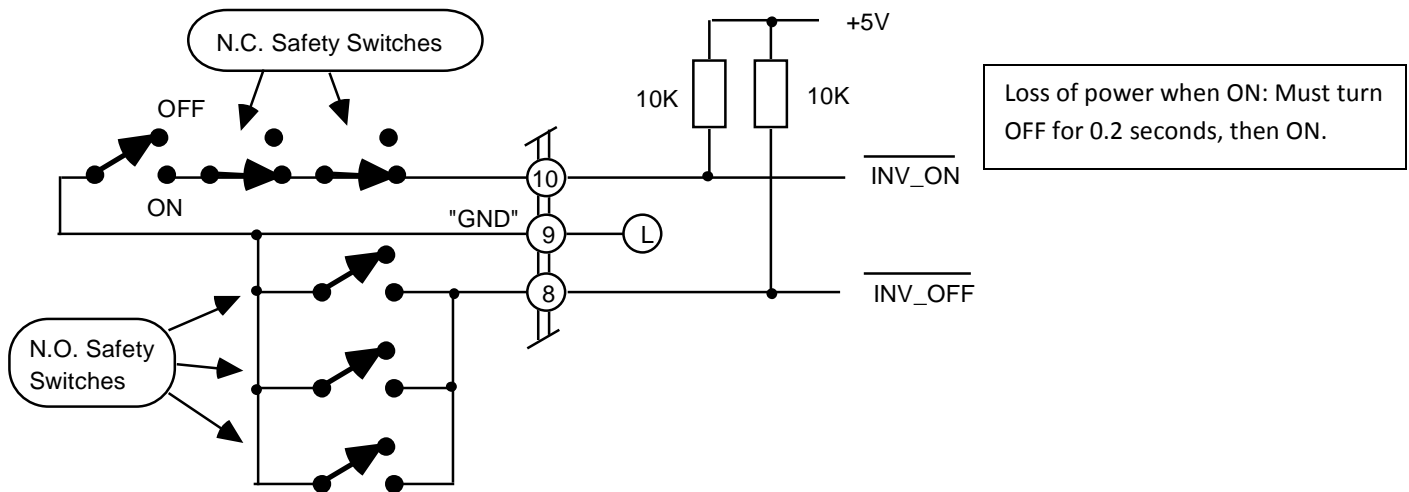

FUNCTION	PWR_UP	J1	J2	J3
To start the inverter the switch must first be in the OFF position, then moved to the ON position for ozone to start.	OMIT	IN	OMIT	X
To start the inverter the switch must first be in the ON position, then power is applied to produce ozone. The inverter will start after the "LED banner flash".	IN	IN	OMIT	X
X = Don't care condition.				
If any of the normally open (N.O.) safety switches goes closed then ozone production cannot start or will cease if operating.				

Power Level Table:

		120/60	208/60	240/60	220/50	
Model	Watts	Amps	Amps	Amps	Amps	
10g	100	.86	.52	.47	.48	
10g	115	.98	.58	.52	.56	
10g	130	1.10	.65	.58	.62	DEFAULT
20g	235	1.97	1.16	1.02	1.10	
20g	250	2.10	1.22	1.08	1.17	DEFAULT
20g	265	2.22	1.30	1.13	1.22	Must be in a cool environment

TROUBLESHOOTING

PROBLEM	STEP	VERIFY	NEXT STEP
ON - OFF switch/PLC control - nothing happens	1	Is there power to the inverter?	No - troubleshoot elsewhere. Yes - Get a voltmeter and do Step 2
	2	Was there 5 seconds between applying power and the ON command?	No - increase the timing between application of power and the ON command. See Section 6 p.18 & 19. Yes - Step 3
	3	+5 VDC between Terminals 5(+) and 3 on CON12 and +5 green LED ON?	No - Check connector seating, broken wires to the small power supply inside the generator toward the rear. Replace supply if necessary. Yes - There is power to the inverter. Step 4.
	4	Verify if the external command output power setting is not at zero. Measure voltage terminals 3 & 5 Connector 12. Verify 4/20 or 0 - 10 VDC control as set by Switch 8 on the inverter board.	No - Step 5 Yes - Increase the ozone output control voltage/current.
	5	If you have gone through steps 1 - 4 without results, it is possible that the inverter board has failed.	Replace the inverter circuit board. Refer to the instruction sent with the replacement to ensure reliable operation.
FAULT indicators on the circuit board are illuminated.			
ALL LEDS flashing	1	Low voltage power supply cycling on and off	Problem with a broken wire, mis-wiring or shorted circuits in the inverter electronics. Look for metal drilling chips caused by contractor drilling. If there, vacuum the electronics thoroughly and retry. If this is not the problem, go to 2.
	2	If there are no other shorts in the system or the system is mis-wired, the low voltage power supply may be defective.	Replace the low voltage power supply.
FAULTED light - Flashing = soft fault temporary condition	1	Caused by: High or Low cell current, high instantaneous current in power section, over temperature in the electronics or cell.	Usually this fault is a result of improper tuning of the inverter beyond factory limits. Go to Step 2
	2	Is the ambient temperature greater than 40 C (104 F)?	Yes - Improve ambient air flow. Inverter will eventually compensate by running at reduced power. No - Go to Step 3

FAULTED light - On solid = Hard fault condition and the inverter is locked OFF IGBT FAULTED	3	Retune the inverter using the procedure in Section 7. Review Section 4.	This should solve the problem if flashing. Flashing is a "call for service" with reduced ozone output.
	1	Look at other fault lights to diagnose the problem. Ozone production is turned OFF.	Go to step 2.
	2	Is IGBT faulted light ON?	Yes - There is a short in the inverter output section that has exceeded the allowable event limit. Look for damaged or loose wires, metal chips, water corrosion or anything that could cause a short. No - Go to step 3
HS TEMP	3	Is HS TEMP faulted light ON?	Yes - Review Status LED description for detail No - Go to Step 4
HOT LOAD	4	Is HOT LOAD faulted light ON	Yes - Review Status LED description Section 6 for detail. No - Go to Step 5
LOAD FAULT	5	Is LOAD FAULT light ON?	Yes - Possible water flooded cell due to the process entering the cell. If the process water is clean, empty the water out of the cell and flush with DI water or 91% alcohol. EMPTY FLUSH WATER FROM CELL! Then dry with very dry oil free air or oxygen for several minutes. Try to operate again. Do not disassemble the cell. Call the factory. No - Go to Step 6.
HIGH POWER	6	Is HIGH POWER light ON?	Yes - Review Status LED description Section 6 for detail.
LOW POWER	1	Is LOW POWER flashing?	Yes - This is non-critical indication that the power is less than the programmed window. No - Go to Step 2
	2	Is LOW POWER ON steady?	Yes - Output current is too low than the programmed window. If this condition remains for more than 32 seconds, a hard fault will shut off ozone and turn on the fault LEDs for diagnostics. Review Status LED description in Section 7 for more detail.

Other problems in your equipment:

The gas inlet solenoid valve chatters rapidly	1	The time delay for the gas pressure switch to operate and keep the valve open.	Yes - Fixed by increasing the time delay in the PLC or controls. No - Go to step 2
---	---	--	---

Ozone output too low and under spec.	2	Gas flow restrictions upstream from the generator or gas pressure too low for the pressure switch.	
	1	Is the PDM control voltage/current correct? Are the jumpers configured right for current/voltage control?	Yes - Go to Step 2 No - Review Jumper Block Configuration in Section 6
	2	Is the oxygen generator producing at least 92% oxygen?	Yes - Did you check this with an oxygen gas analyzer? You need more than 90% O2. Don't know - If an analyzer isn't available, get an oxygen bottle from a welding shop or compressed gas supplier. Install the bottled gas instead of the PSA oxygen generator. No - Go to Step 3
Inverter may or may not show a fault but NO ozone output detected	3	Is there process water in the cell? The DAT 310 inverter may be faulted too.	Yes - See Troubleshooting comments under LOAD FAULT for remedy. No - It may be necessary to return the entire generator for analysis. Call the factory.
	1	Was there a vacuum pulled in the cell by the injector with inverter power applied?	Yes - The cell(s) must be returned to the factory and be rebuilt. They cannot be field repaired due to excessive damage. Check to see if the gas inlet valve was closed while the injector was running and inverter power was applied. This is a common process design mistake. The cell should have no less than 5 psi with power applied. No - Go to step 2
	2	Is the PSA oxygen generator undersized or marginal causing it to run near maximum capacity?	Yes - This is another common process mistake. The cell may be full of PSA resin and needs to be cleaned. A HEPA filter on the PSA oxygen outlet is good practice and may be necessary. No - Go to step 3
	3	Has the ozone monitor sufficient sample flow. Most monitors require about 1 LPM to operate?	Yes - Call the factory. The usual causes have been covered but there are other process considerations. No - Or no monitor available. Call the factory for further instructions.

% Weight vs. Power Consumption

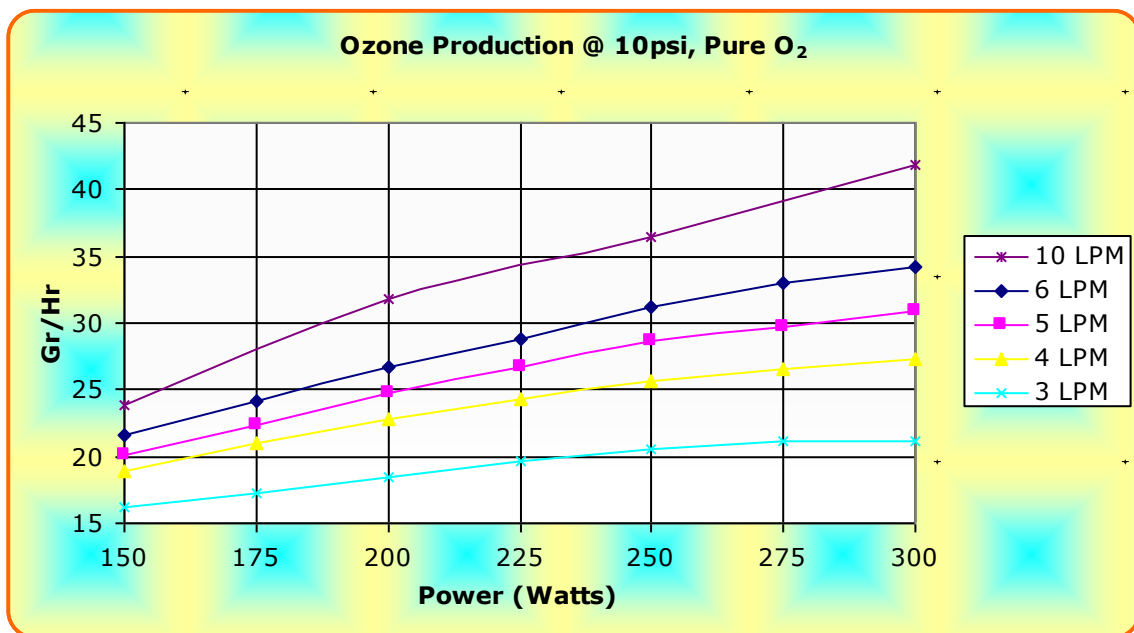
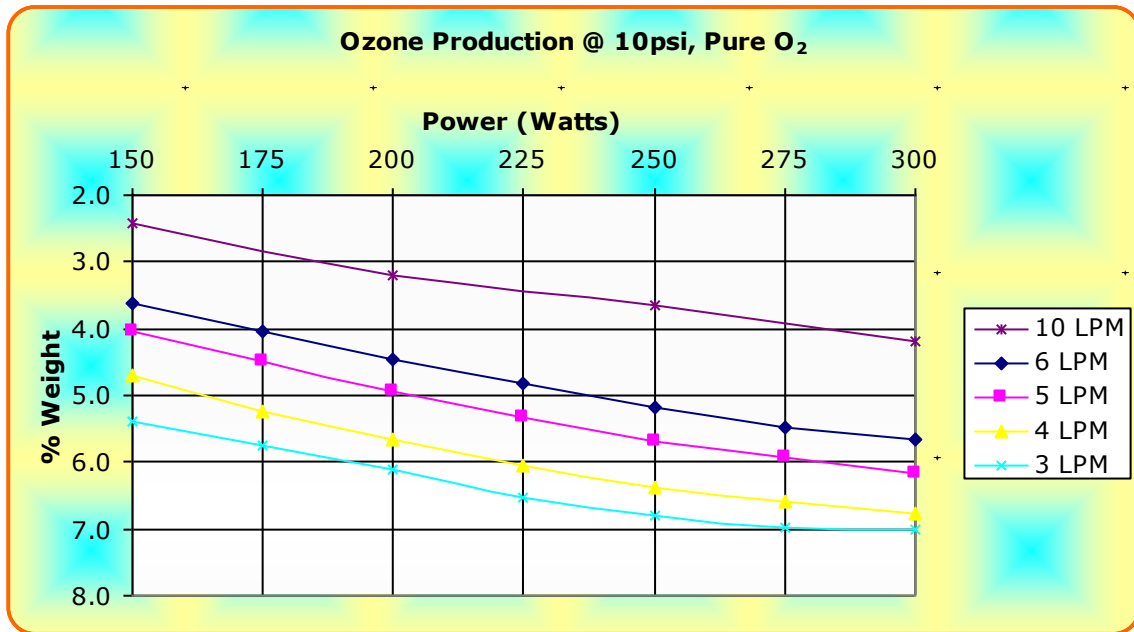

Grams / Hour vs. Power Consumption

Best performance at about 12 psi. LPM flow via uncorrected

Rotameter, all pressure readings in psig.

Performance Information:

Grams / Hr vs. PDM Control Voltage

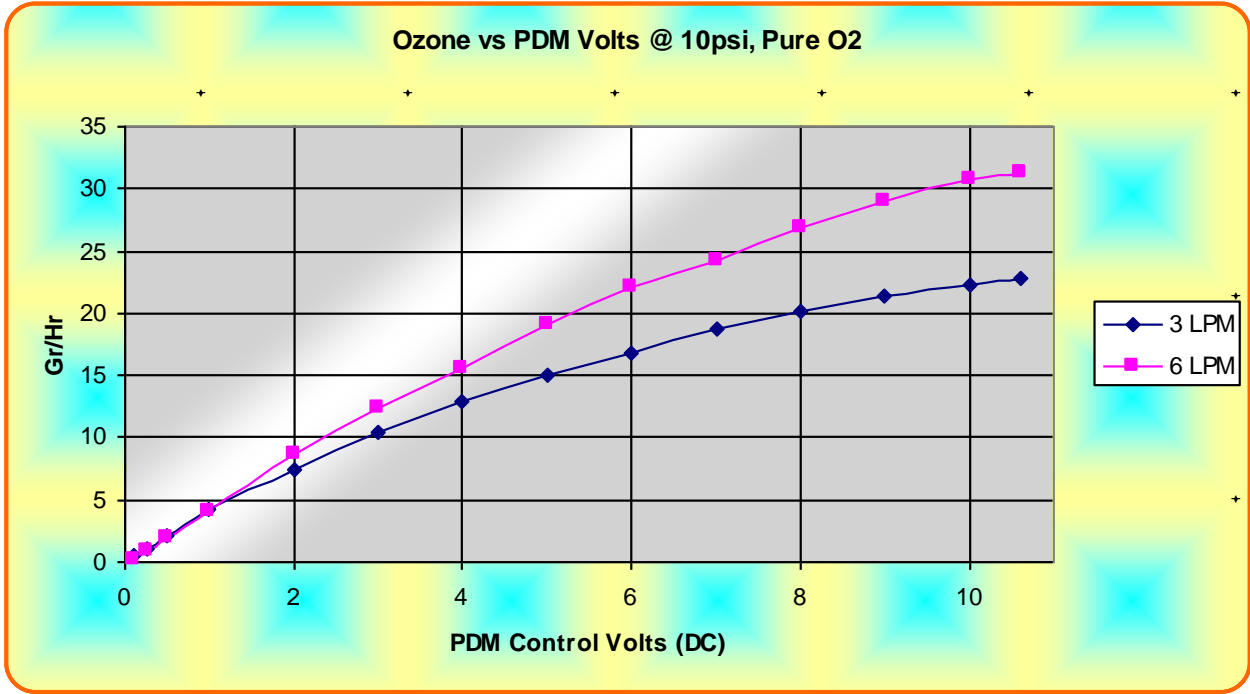

Non-linearity due to cell heating as power is increased.

Performance Information:

% Weight vs. Grams / Hour

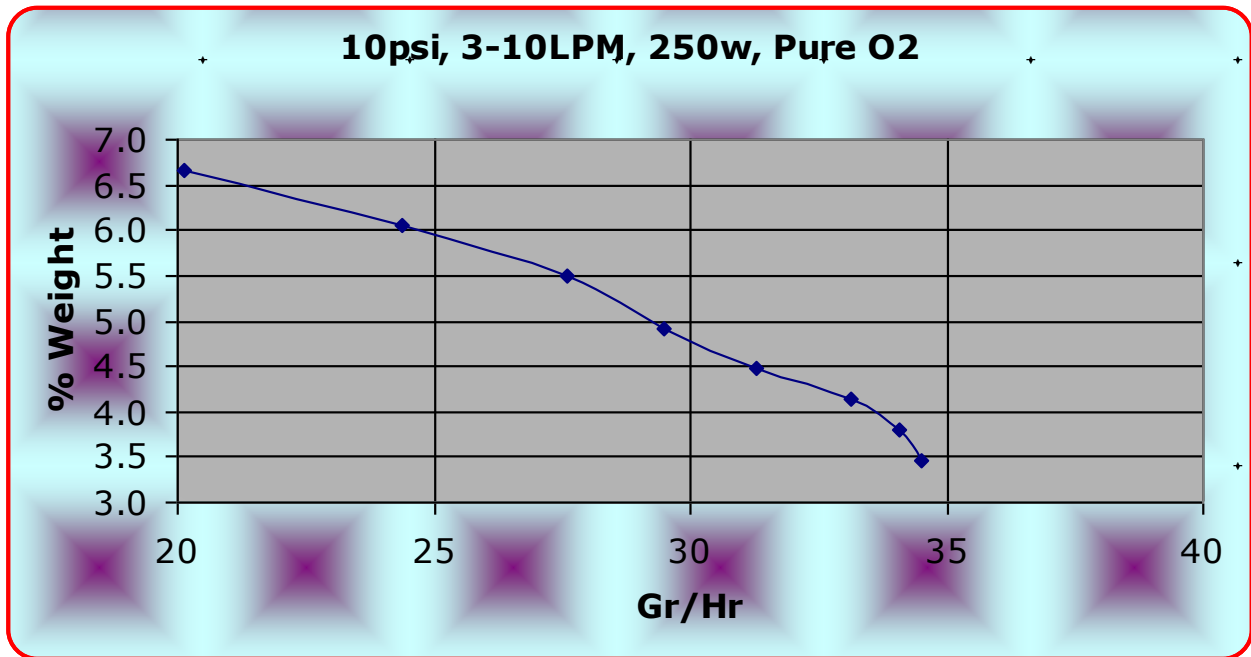

Left to right, 3 to 10 LPM, 1 LPM per data dot.

Flow Rate vs. Grams / Hour

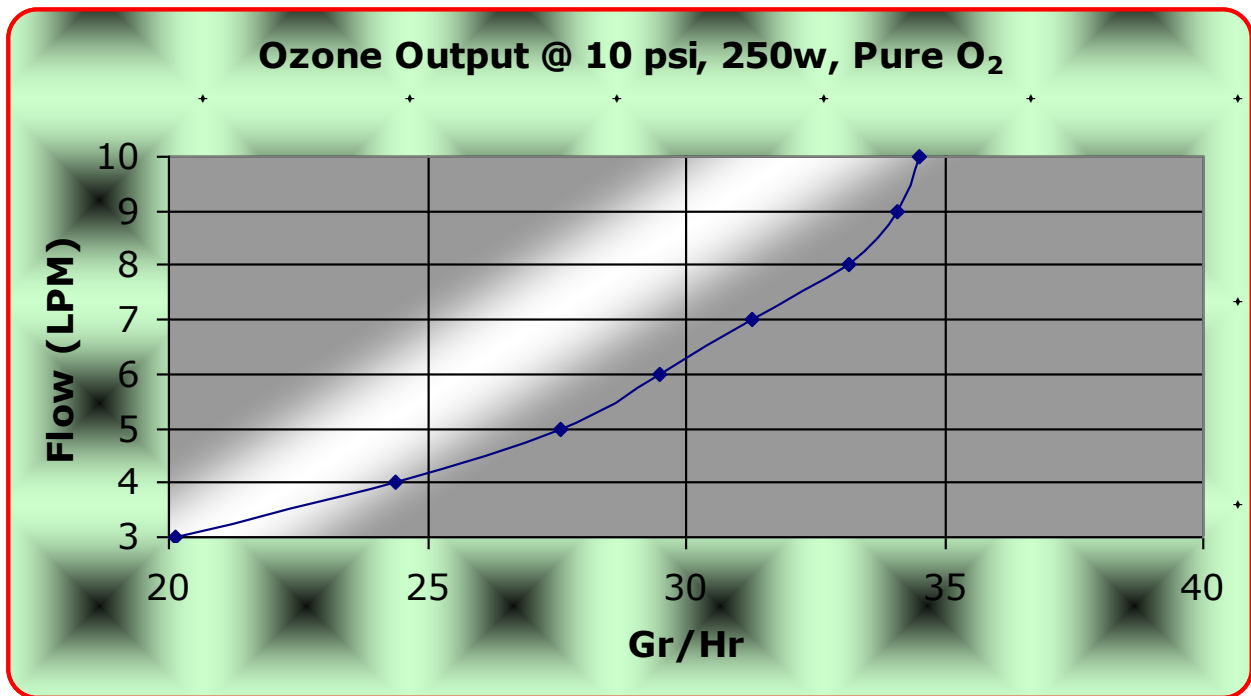

Flow Rate vs. % Weight

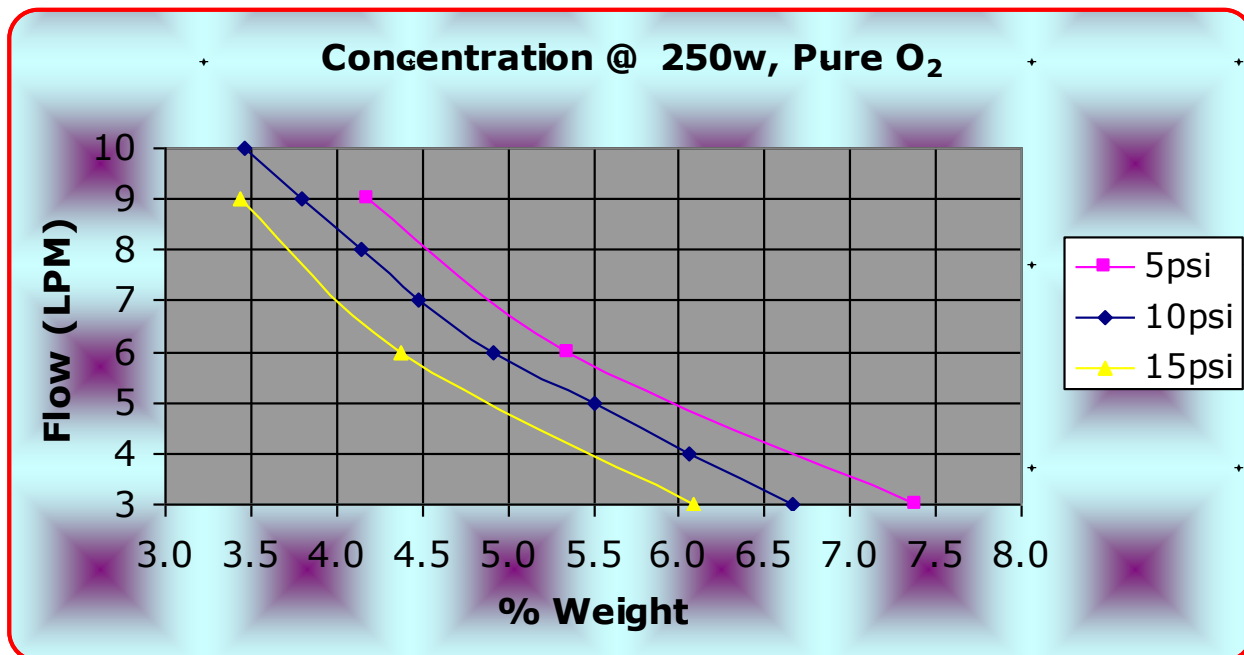

Flow Rate vs. Pound per Day

