



DAT210

70250 INVERTER ASSEMBLY



Table of Contents

Section 1	Reasons for specifying the assembly	3
Section 2	Circuit description	4
Section 3	Bill of Materials	4
Section 4	Dimensions	5
Section 5	Disclaimer	6

Please refer to the DAT 210 or SSD 110 manuals for inverter specific installation and operational details.

SECTION 1.

REASONS FOR SPECIFYING THE ASSEMBLY

The DAT210 inverter component is designed with a single phase line rectifier providing pulsating direct current (DC) to large input filter capacitors. If the line is connected directly to the line input of the inverter, there will be an initial large inrush current to charge the capacitors. This current is only limited by the mains source (wiring and utility transformers) and filter capacitor internal resistance. The effect is particularly pronounced when the inverter is operated from 240 VAC single or 3 phase at power over 1 KVA.

There are three disadvantages to directly connecting the line to the inverter.

1. High inrush can stress the filter capacitors shortening its life.
2. High inrush currents can stress the safety circuit breakers (and will blow fuses) that may work fine during testing but will deteriorate over time causing nuisance trips.
3. Connecting any rectifier filter capacitor directly to the line causes a strong 3rd harmonic line current causing a 0.6 power factor. Many companies prefer clean (low harmonics) devices in their facility to lessen interference with other more sensitive equipment.

The 70250 inverter assembly solves these problems. A soft-start relay circuit is automatically controlled by the inverter, pre-charge components limit inrush currents and a high current link choke to eliminate the harmonics and correct the power factor to 0.95.

Lastly, the assembly is cost effective by eliminating the need to individually design and mount these essential components.

SECTION 2. Suggested soft start circuits

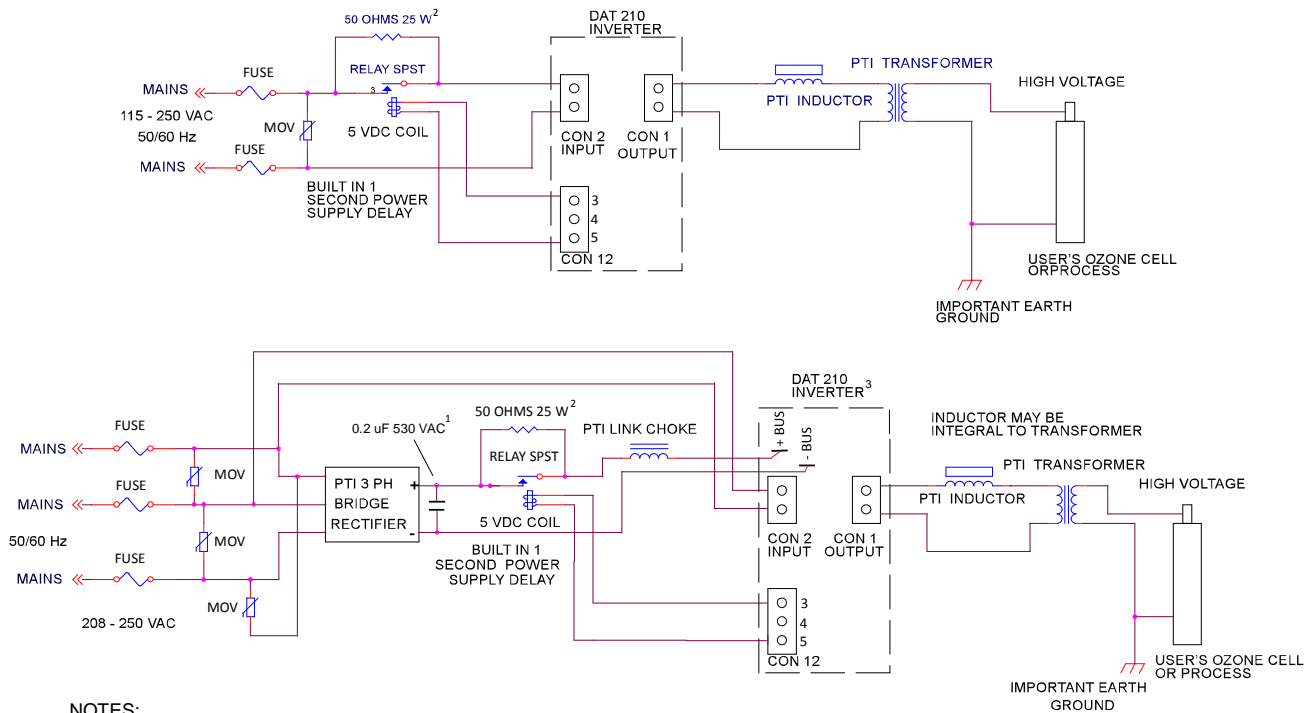

- NOTES:
1. PREFERRED: ASC CAPACITORS U1C1
 2. PREFERRED: CERAMIC RESISTOR HVRAPC U2125A330L
 3. THE DAT210 BRIDGE RECTIFIER IS REMOVED FOR 3 PHASE MAINS AND D.C. POWER.

Circuits are shown for both single phase (top) and three phase inputs (bottom). Components to the right of the inverter are typical ozone generator components.

A general rule is to use the three phase circuit assembly 700250 if the generator is rated over 2 KW. However this is a matter of individual preference. If the generator is over 3 KW, use the 700250-1 for a higher current DC link choke.

Section 3 Bill of Materials

INVERTER 70250 ASSEMBLY					
QUANTITY	PART NO.	DESCRIPTION	SOURCE	NOTES	
				716.693.4700	
1	U2125A330L	Ceramic surge resistor	HVRA	www.hvrapc.com	
				866.433.5722	
1	W9AS1D52-5	30 Amp 5 VDC coil relay	Magnecraft	www.alliedelec.com	
1	DF30AA160	30 Amp three phase rectifier	SanRex	516.625.1313	
				308.284.3611	
1		0.2 uF 1600 VDC/530 VAC capacitor	ASC or PTI	www.ascapacitor.com	
1	235	14 Amp DC link choke (inductor)	PTI	3 KVA maximum	
1	237	20 Amp DC link choke (inductor)	PTI	> 3 KVA use the 237	
1	DAT210	Inverter to 4 KW	PTI	Purchased separately	

Section 4 Dimensions

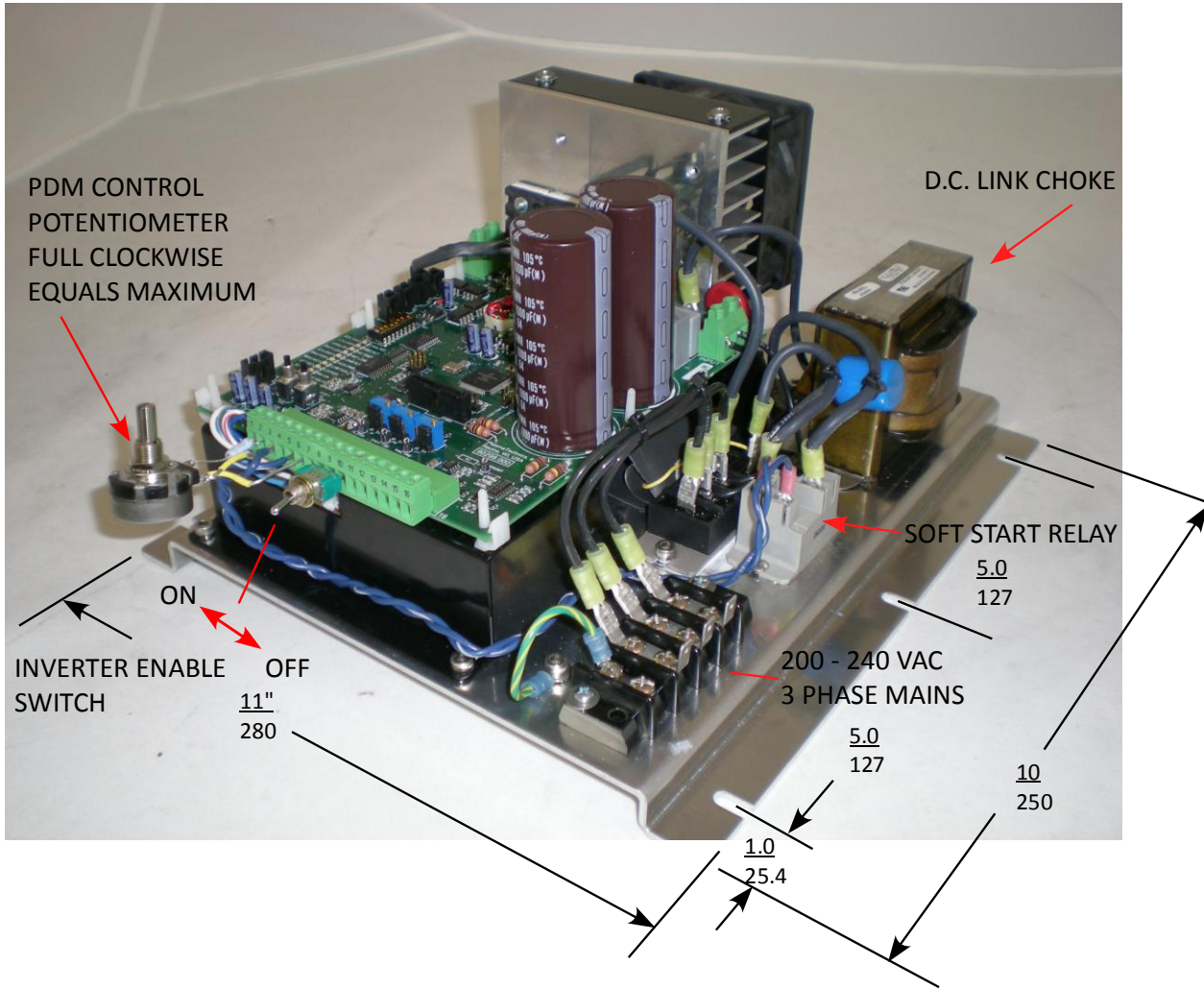

PLEASE REFER TO THE DAT210 MANUAL FOR ADDITIONAL DETAIL

P/N 70250 DAT210 INVERTER ASSEMBLY

Features include:

- Soft start feature
- Power factor correction to 0.95 pf
- Prewired
- Extends the filter capacitor life

(3 phase 700250 inverter shown)

Section 5

DISCLAIMER

Plasma Technics, Inc.® (PTI) assumes no responsibility or liability for specific applications results. PTI supplies only components for ozone systems and not the complete system. The complete system is the responsibility of the ozone system manufacturer and/or others involved in a specific project.