



INSTALLATION & OPERATION MANUAL DAT 210 INVERTER

Digital Auto Tuning



AppnoteDAT210 v4g

Plasma Technics, Inc.®

1900 William St
Racine, Wisconsin 53404-1875

Office : (262) 637-7180
Fax : (262) 637-7157

Web: www.plasmatechnics.com
E-Mail: sales@plasmatechnics.com

Copyright © 2009 by Plasma Technics®, Incorporated.

All rights reserved. No part of the publication may be copied, reproduced, or reduced to any electronic media or machine-readable format without the prior written permission of Plasma Technics Inc.®

NOTE:

THIS MANUAL COVERS THE DIGITAL AUTO TUNING (DAT210) INVERTER FOR OZONE GENERATOR SERVICE.

The information contained in this manual is considered accurate to the best knowledge of the supplier at the time of publication. The manufacturer, however, assumes no liability for errors that may exist. The supplier reserves the right to change data and specifications without notice.

Document Reference: AppnoteDAT210 v3a December 23, 2009

PCB I.D. Label: 90299.000

Table of Contents:

	PAGE
1. UNPACKING	5
1.1 VERIFY DELIVERY.....	5
1.2 INSPECT FOR DAMAGE.....	5
1.3 AFTER THE INITIAL INSPECTION.....	5
2. MECHANICAL MOUNTING.....	6
2.1 MOUNTING ENVIRONMENT	6
2.2 MOUNTING CONSIDERATIONS	6
2.3 HOW TO MOUNT THE INVERTER	6
2.4 MOUNTING DIMENSIONS.....	7
3. ELECTRICAL INSTALLATION	7
3.1 WIRING STANDARDS AND CODES	7
3.2 INVERTER ELECTRICAL CONNECTION WIRE SIZING	8
3.3 CASE GROUND	8
3.4 SAFETY GROUNDING.....	8
3.5 SOFT CHARGE	8
3.6 SURGE AND CURRENT PROTECTION	8
FIGURE 3.1 INVERTER LAYOUT DESCRIPTION.....	9
4. INVERTER COMPONENT SELECTION AND CALCULATIONS.....	10
4.1 RATINGS AND MEASUREMENTS	10
4.2 OUTPUT VOLTAGE CALCULATIONS.....	10
4.3 PDM POWER CONTROL.....	11
4.4 OUTPUT FREQUENCY CALCULATIONS	11
4.5 OUTPUT RATE OF CHANGE CALCULATIONS.....	11
5. LOW POWER CONNECTIONS.....	12
5.1 LOW POWER CONNECTION DIAGRAM	14
5.2 SWITCH AND JUMPER BLOCK CONFIGURATION CHART	15
5.3 SWITCH AND JUMPER BLOCK DESCRIPTION	16
5.4 METHODS OF ON - OFF CONTROL.....	18
5.5 AUTO/MANUAL TRANSFER SWITCH AND MULTIPLE INVERTER CONTROL	21
6. OPERATING CONDITION LIGHTS (LED STATUS).....	22
7. APPLICATIONS.....	25
7.1 PROCESS SCHEMATIC (TYPICAL).....	25
7.2 INVERTER ASSEMBLY P/N 70250.....	25
7.3 TRANSFORMER CONSIDERATIONS.....	26

8. START-UP.....	27
8.1 SAFETY CONSIDERATION.....	27
8.2 START-UP CHECKLIST.....	27
8.3 START-UP PROCEDURE POWER ADJUSTMENT.....	28
METHOD 1 FOR PLASMABLOCK ADJUSTMENTS.....	28
METHOD 2 FOR OTHER MANUFACTURERS CELLS/EQUIPMENT.....	29
9. TROUBLESHOOTING.....	31
10. NOTES & GENERAL INFORMATION.....	33
11. WARRANTY.....	34

Section 1 Unpacking

1.1 Verify delivery.

Check that you received the inverter and optional equipment that was ordered. Verify that the part numbers match your purchase order and that the correct options have been installed. Report any discrepancies to your supplier.

1.2 Inspect for damage.

Inspect the inverter for damage that may have occurred during shipment. Visually examine the contents for obvious problems. If damage is found, do not operate the inverter. Report the problem immediately to your supplier.

1.3 After the initial inspection.

Your inverter can be repacked and stored for future use. Choose a storage location that is clean and dry. Do not store in ambient temperatures below 5° F or above 158° F (-15°C to 70° C) Do not store in wet areas or areas of high condensation. Do not store in corrosive environments.

Section 2 Mechanical Mounting

Proper mechanical installation of the DAT210 is necessary to ensure both reliable and efficient operation and ease of maintenance.

2.1 Mounting Environment

The inverter should be mounted in an environment that is **free** from the following:

!Corrosive or volatile vapors. Dust and particles, Excessive moisture.

!Shock, Excessive vibration, Temperature extremes!

The following environmental specifications apply:

Surrounding air ambient operating temperature: 0° to 40° C (32° to 104° F)

Relative humidity: 5 to 90%, non-condensing.

Altitude (maximum): 1,000 M (3,310 ft), de-rating for altitude is 1% for every 100 M (300 ft) above 1000m.

2.2 Mounting Considerations

The following should be considered when planning the physical installation of your DAT210.

Leave enough clearance for access to all electrical connections.

Allow room for troubleshooting.

Allow at least 80 mm (3 inches) of clearance above and below the unit to permit adequate cooling airflow.

The DAT210 **must be fan cooled** in order for the inverter to be run at full output power. Consult the factory for heat sink only de-ratings or fan placement. It is recommended that applications requiring input currents above 10 amps RMS be fan cooled. In the final installation the convection cooled DAT210 should be mounted with the cooling fins vertical so as to maximize the affects of normal convection cooling. The cooling fan can be mounted in any orientation. Allow a minimum clearance of 25 mm (1.0 in.) between units when mounted side by side. Separate conduit is required for line voltage and control wiring.

2.3 How to Mount the Inverter

Figure 2.1 shows the mechanical layout of the DAT210 inverter. Refer to this drawing when planning your layout. The DAT210 is an open type of equipment and should be mounted to a secure sub-panel or frame.

CAUTION:

Make sure the mounting rack is secure before mounting the inverter. Equipment damage could result from an improperly mounted rack or inverter.

Figure 2.4

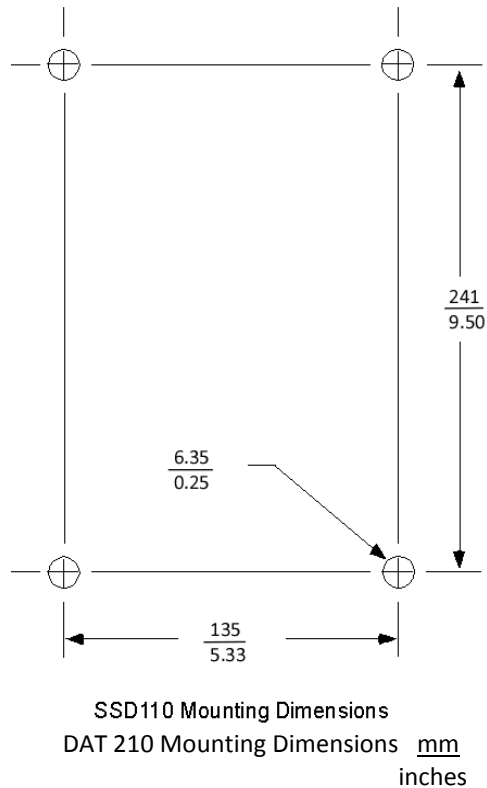

Section 3 Electrical Installation

3.1 Wiring Standards and Codes

The installation person is responsible for following the wiring plan produced by the design engineer for the specific application.

All wiring must conform to the following standards:

National Electrical Code, Publication NFPA No. 70

All local and national codes which apply

For motor usage; use appropriate NEMA relay for protection

The supplier cannot assume responsibility for the compliance or noncompliance to any code governing the proper installation of this equipment.

3.2 Inverter Electrical Connection Wire Sizing and Fusing

The DAT210 input current rating is 25amps RMS. Use branch circuit fuses suitable for use on a circuit capable of delivering not more than 25rms symmetrical amperes, 250 volts maximum. Output current rating is 15amps RMS. Refer to the National Electrical Code [NEC], Publication NFPA No. 70, Article 310, and any local codes that may apply for wire sizing and selection. Use 60/75°C wire min. and 25 amp input fuses of class K5 or RK5.

Terminal connection max torque 0.6 newton meters (Nm) [5.3 inch lbs].

3.3 Case Ground

Each of the inverters must be connected to ground at their case ground terminal. A grounding electrode conductor or bonding jumper must be connected from the ground terminal to either a grounding electrode buried in the earth or a suitable plant ground with solid connections to earth ground. Refer to NFPA No. 70, Article 250, for details on grounding and grounding electrodes.

3.4 Safety Grounding

The case ground connections should be made at the ground terminals. The case ground of the various system components should be connected to the star grounding bus of the cabinet. A grounding electrode conductor or bonding jumper must be connected from the star grounding bus to either a grounding electrode buried in the earth or a suitable plant ground with solid connections to earth ground. Refer to NFPA No. 70, Article 250, for details on grounding and grounding electrodes.

3.5 Soft Charge

While direct line starts are permissible, a soft charge circuit will extend the life of the filter capacitors, see Section 7 Applications. High input surge currents can be reduced by using one 50-ohm resistor for a single-phase input. The resistor should be bypassed by a time delay relay contact(s) approximately one second after the power is supplied to the resistor. This soft charge procedure will increase the bus capacitor life.

3.6 Surge and Current Protection

While the DAT210 has an on board surge suppressor (MOV), the customer can add surge protection to protect the inverter devices from line spikes. See Figure 7.1 for connection diagram. Contact your surge suppression supplier for sizing details. The DAT210 utilizes an on board current limiting circuit. The circuit performs current limiting when a potentially destructive current value is detected. If this event occurs the DAT210's output section will automatically shut off.

Figure 3.1
Inverter Electronic Layout Description

DAT210

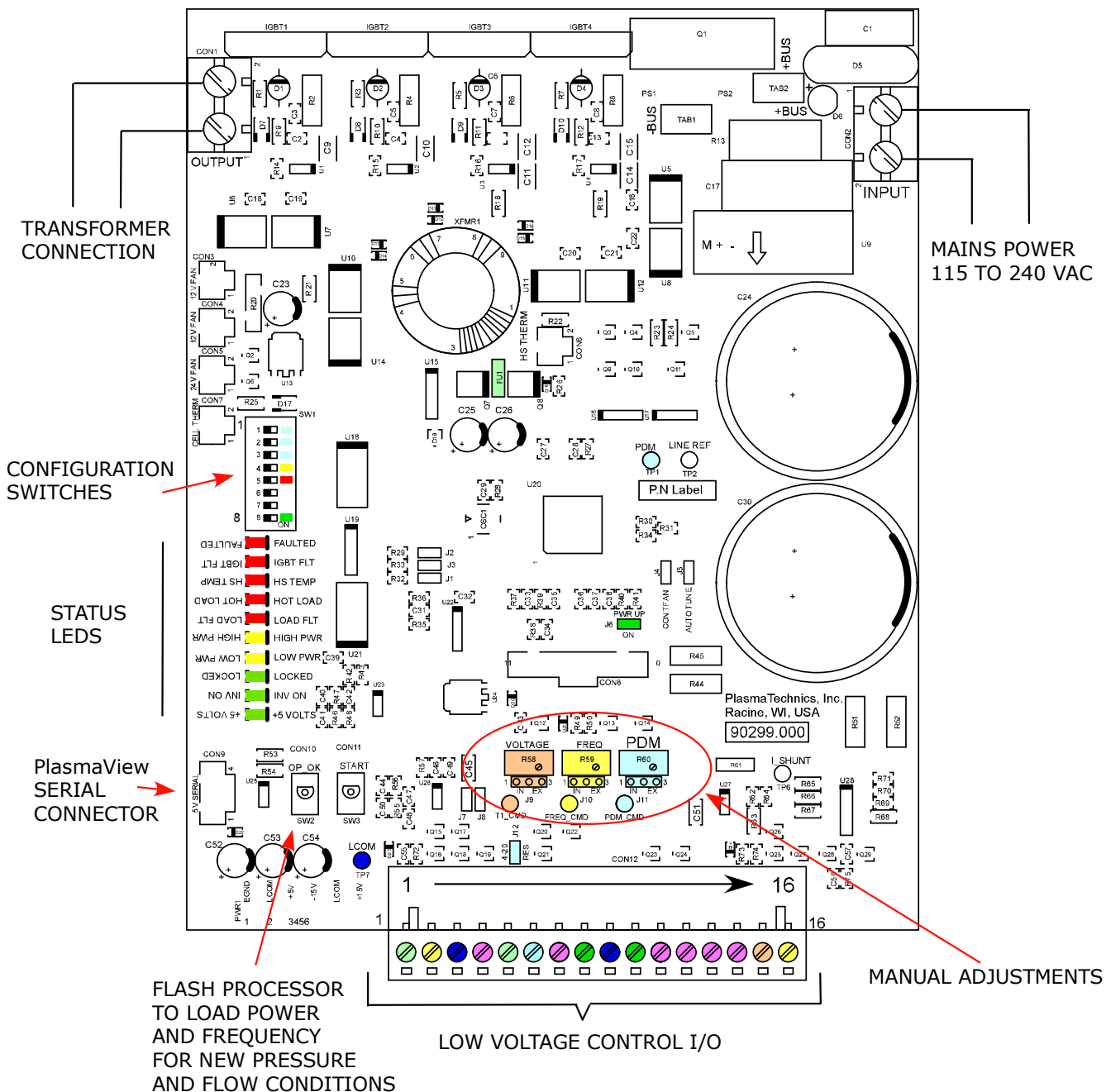

Section 4 Inverter Component Selection and Calculations Detail

4.1 Ratings and Measurements

It is very important to measure, evaluate and understand the electrical performance of the system.

Wattage can be either measured or estimated using the generally accepted premise for DC supply devices. In this example the single-phase power line input to the Inverter is supplying 15 amps:

$$\text{Watts} \approx (\text{Volts} * \text{current}) * .65$$

$$\therefore (240\text{v} * 15\text{a}) * .65 = 2340 \text{ watts}$$

The general rule for any type of transformer that determines the maximum primary amps **regardless** of applied primary volts is: **Nameplate VA / Configured Volts (not applied volts)**

Example: 1000va / 240v = 4.17a max or 3000va / 240v = 12.5a max.

Note that maximum primary amps is not related to applied volts. If the applied primary voltage is 50% of the rated value then the VA rating of the transformer has effectively been cut in half.

To continue with this example, if the expected ozone performance is being achieved with 50% of rated primary voltage then it is likely that the output voltage rating of the transformer is twice as high as it should be. Under these conditions the inverter input current could be well within its rating but the transformer could be at twice its rated primary current. This is why it is essential to also measure the transformer primary current. If a voltmeter is available rather than an amp meter then the primary current can be reasonably estimated by taking the inverter input watts and dividing it by the measured primary volts. For the purpose of this example 200vac is measured. Using the above numbers: 2340w / 200v = 11.7a.

You can see this 11.7a is nearly the rating of the transformer, which in this configuration is 12.5a.

Note: If the frequency control is going to be substantially increased it is recommended that the pulse width (voltage) control be reduced first.

4.2 Output Voltage Calculations

The RMS output line-to-line voltage (VLL) and its maximum value are partially determined by the input voltage. The Approximate maximum output voltage is calculated by using Equation 4.2.

Equation 4.2

$$V_o \text{ (RMS) Max} = 1.1547 * V_i \text{ (VRMS) or}$$

$$V_o \text{ (RMS) Max} = 1.1547 * V_i \text{ (VDC)} / \sqrt{2}$$

The output voltage (VLL) is determined by the pulse width (Tp), at a selected Frequency (f). The pulse width (Tp) is set by a voltage from the voltage adjust to the micro-controller.

4.3 Pulse Density Modulation (PDM)

As shown in Figure 4.1, the high frequency is turned ON and OFF at a low frequency rate. Varying the percent ON time vs OFF time gives a very linear control of output power. The technique allows a high turndown ratio of at least 100:1 (1% to 100% output).

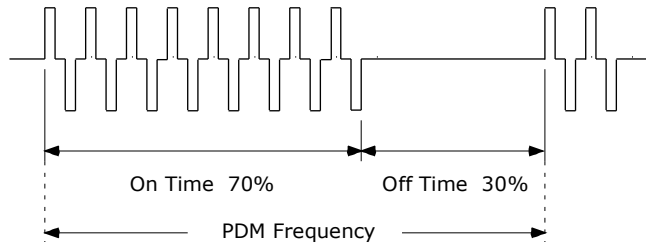

Figure 4.1

This adjustment can be made either with an external potentiometer as shown in the Low Power Connections with J11 in the EXT position or with the board potentiometer if J11 is in the INT position.

The normal method is with an external potentiometer or PLC. The voltage on terminal 6 controls the PDM ozone output. If J12 is OUT, the input is 0 – 10 VDC. If J12 is IN, the input is 4 – 20 ma or 0 – 20 ma. with ozone production starting at about 4.1 ma.

4.4 Output Frequency and Voltage Adjustment

The external voltage applied to the micro-controller can control the output frequency if jumper J10 is in place and an external potentiometer is added to terminals 1, 15 & 3.

With the jumper J9 in the INT position, the voltage is controlled with the PC board potentiometer.

Normally there is no need for these adjustments as they are controlled by the firmware automatically. Automatic frequency adjustment is necessary to automatically compensate for minor gas flow and pressure variances.

4.5 Output Rate of Change Calculations

The output frequency, if controlled by the frequency potentiometer ramps down from a high frequency to the established expected frequency for control. Normally there is no need for this adjustment as it is controlled by the firmware automatically.

Section 5 Low Power Connections

Input / Output Connections (Con12)

Basic control connection for PDM, ON/OFF, Frequency, Voltage, Enable out, +15vdc, +5vdc are the same as all other Plasma Block® products that have utilized the DAT210 control board. Note below that many new outputs are available and the enunciation outputs have been changed from 0-5v logic level types to open collector for easier interface to a wider variety of PLC's. The open collector outputs are all active low [Active low means that the terminal output is at 0V (Pin 3) when the alarm or other condition is present]. Terminal current is positive source only and is limited to 100 ma.

TERMINAL

1. +15, aux use limit = **1 Amp maximum**.
2. Frequency Adjust (optional) external control, selected by jumper J10. Use 5k Ω pot, 0-10vdc only (10v= 100%). 10 volts can be derived with a 2.0 K resistor in series with the pot to +15 (Pin 1).
3. **Signal Common**, tied to #9 internally.
4. Flooded cell detector. (Current production inverter)
5. +5vdc, aux use limit = **3 Amps** **The 5V can be used to drive a 5 V coil relay for input current pre-charge and for PLC use for low voltage power supply status. There is a 1 – 2 second delay before +5 V after application of mains voltage.**
6. **PDM input** (optional), selected by jumper J11, use 5k Ω pot, 0-10vdc (10v= 100%). 10 volts can be derived with a 2.0 K resistor in series with the pot to +15 (Pin 1). 0 – 10 volt control or 4 – 20 & 0 – 20 ma is selected with J12. All voltages/currents are with respect to Pin 3 (0V).
7. **Inverter Start**, output pulls low via open collector (MMBT4401) when inverter is engaged. Follows Inv_ON LED. 10k Ω pull-up to +5. 100 Ω in series with the transistor for current limit.
8. **Inverter OFF** when pulled low to terminal 9 via momentary or continuous. 10k Ω pull-up to +5v.
9. **Logic Common** for # 8 and 10.
10. **Inverter ON** when pulled low to terminal 9 via momentary or continuous. 10k Ω pull-up to +5v.
11. **FAULT OUT** pulls low via open collector (MMBT4401) when inverter faults due to: Operating cell current is above or below customer programmed set point. Over temp cell, over temp electronics, sustained instantaneous over current. 100 Ω on board. (See jumper J4)

12. System LOCKED. Digital auto-tune feature has found and confirmed the proper operating point. If pressure changes cause significant re-tuning the LOCKED LED will flash. The locked LED will also flash during the initial tuning acquisition, which lasts for a few seconds.
13. Analog 0 – 5vdc, follows average DC bus current out. Direct op amp (MC33272AD) thru 100 Ω resistor.
14. Analog 0 – 5vdc, follows DC bus voltage. Direct op amp (MC33272AD). 10k Ω series resistor.
15. Voltage Adjust input (optional), selected by jumper J9, use 5k Ω pot, 0-10vdc only (10v= 100%), impedance 10k Ω .
16. Clock Freq out (1x). Output pulls low via open collector (MMBT4401). 10k Ω pull-up to +5. 100 Ω series protection resistor.

DAT210 Connections

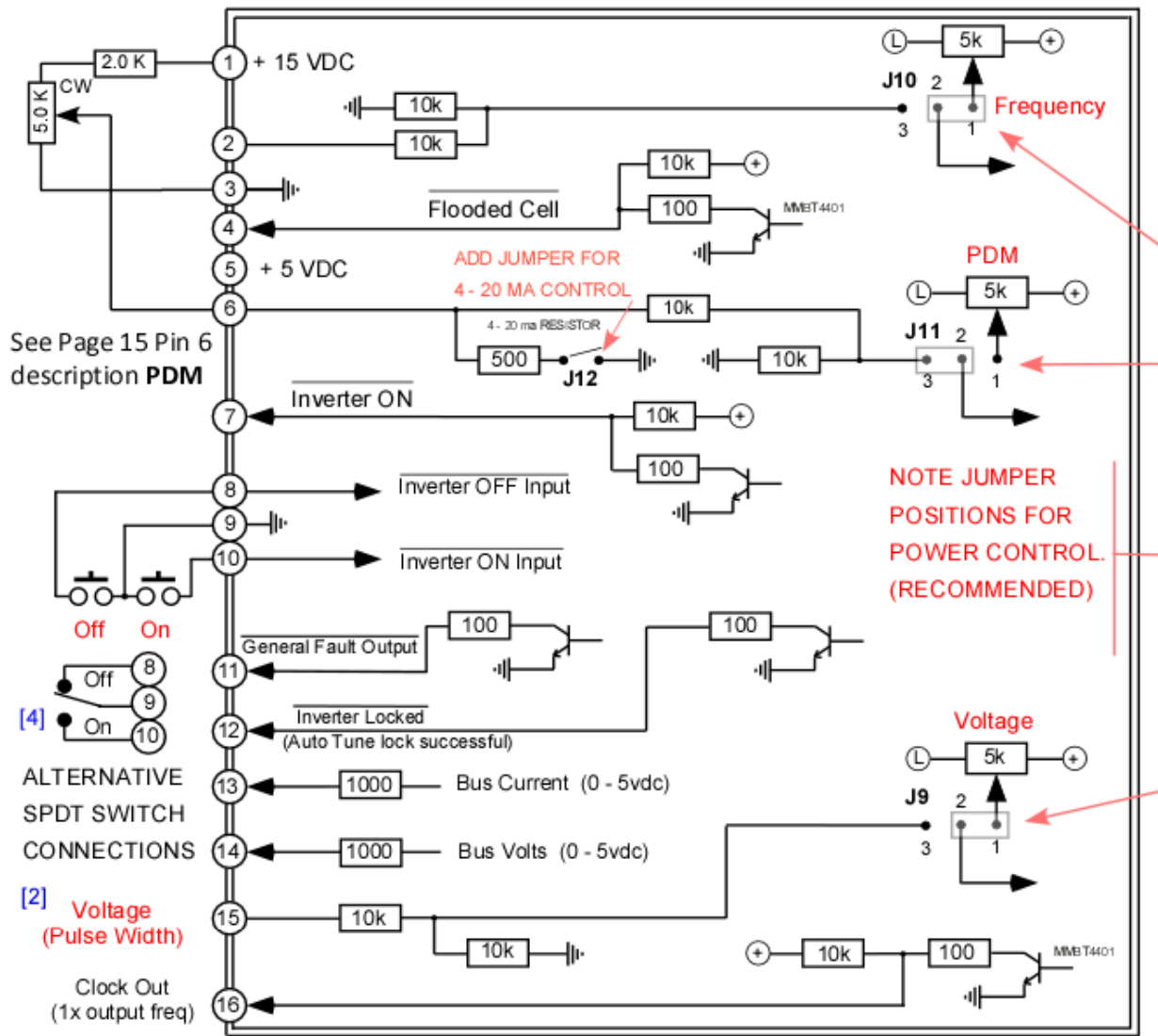

- Grounding either #3 or #9 is not necessary and usually controlled by PLC.
- External pots for frequency and voltage should be multi-turn, cermet substrate types for stability and precision. Rating of 1/4 watt.
- Shielded cable recommended for connection runs of 2' or more.
- [1] Optional but recommended (1/4w) to obtain full use of potentiometer range.
- [2] External pot 5k, 2000 ohm resistor recommended as per note 1.
- [3] Ground symbol represents circuit board floating common, not earth grounded. Best to leave floating or allow PLC to establish the ground relationship.
- [4] Optional SPDT toggle switch or relay.

5.2

DAT 210 JUMPER CHART

SWITCH			
SW1	SWITCH POSITION	NAME	FUNCTION IF INSTALLED
S1	ON	PDM Enable	If PDM is remotely commanded, remove to test 100% output level. This is especially useful if the unit is hard wired to a PLC or ORP controller.
S2	OFF	LOW PDM	Lower PDM period than 30 Hz
S3	OFF		Not implemented
S4	ON	HIGH/LOW current fault	A window of normal operating current. This will cause a fault if either the LOW or HIGH value is exceeded.
S5	OFF	Soft fault	Produces a wink in fault line #11 if one or more operational windows are exceeded beyond the factory limit. Will not shut down the inverter like a hard fault but attention is needed. The fault is being managed by the inverter processor.
S6	OFF	PDM Ramp	Default – 5 sec. for inverter to ramp from 0 – 100% power. Switch ON is immediate ramp to 100% inverter power.
S7	OFF		Spare
S8	OFF	4/20 ma.	Configuration for 4 - 20 ma. control 0 - 100% ozone output. At 2 ma the INV_ON LED will flash. At 3 ma. The output is reinabled. If the jumper is removed, 0 - 10 (0 - 100%) volts controls the ozone output. If the command is for zero ozone, the inverter will be in standby.

JUMPER	INSTALLED DEFAULT		
J101	OUT	ON with power up	ON-OFF command change. The inverter will turn ON 5 seconds after power is applied and turned OFF when power is removed. This is not recommended because it eliminates gas purge.
J1, J2			Alternate methods of inverter startup. See Pages 17 – 19.
J3	OUT	SEMI-AUTO Tune	J5 out, voltage pot active to set maximum power. Frequency control is automatic.
J4	OUT	Manual fan	Fan goes on when power is applied and off when removed.
J5	IN	Full AUTO-TUNE	Voltage and frequency pots are not active. These parameters are controlled automatically. In SEMI-AUTO mode, the voltage pot controls total power but frequency control is automatic.
J9	IN	Voltage control pot	1 - 2 jumper = internal control. 2 - 3 = external
J10	IN	Frequency control pot	1 - 2 jumper = internal control. 2 - 3 = external
J11	IN	PDM control pot	1 - 2 jumper = internal control. 2 - 3 = external
J12	*Stow	Installed = 4/20 ma. Or 0/20 ma. OUT = 0 - 10 VDC	Adds 500 ohm resistor to control input. If two or more DAT 210s are to be controlled via one current loop, wire all Connector CON12 term. 3 together and all term. 6 together and install J12 on <u>one</u> DAT 210 inverter. Usually S8 ON and J12 jumper are used together.

*Jumpers that are available for customer needs are stored on one pin.

Controls and switches

Control Potentiometers (Pots)

PDM — The onboard Pulse Density Modulation control pot is primarily of use for simple applications running at a fixed turndown level and is helpful for bench testing. Use jumper J11 to select on board (IN) or external terminal strip control (EX). Normally terminal #6 input delivers a voltage or current to the unit, which manages a closed loop process ozone level.

Voltage — Adjusts voltage applied to cell. Use jumper J9 to select onboard (IN) or external terminal strip control (EX). This control is used to set the maximum power operating point for the unit while in the Semi-Auto mode, but is not observed in the Full-Auto mode. Remote operation is via terminal # 15. If external control is used, it must be a voltage from 0 to 10vdc, unless a 2.0 K ohm resistor is added to terminals 3 and 15. No 4/20ma current control jumper provisions exist on the PCB.

Frequency — Adjusts cell frequency. This pot is factory set and not observed unless the unit is in the factory set-up configuration. Frequency is dynamically managed by the processor for both Semi and Full Auto modes. Provisions have been made for remote control via terminal # 2, in which case J9 should be in the (EX) location and J3 is installed.

Switches

Op_OK — This switch has two uses. Additional information is available in the detailed description.

1. When the inverter is ON and J5 is OUT, stores the present running parameters of voltage, frequency range, current tolerance along with other internal configuration information available, as **normal** field operation. This information becomes the re-start information after an OFF - ON power cycle.
2. Recalls the factory set-up table to active memory when the inverter is powered up but OFF. The factory table is never overwritten and can be recalled as a last resort if the unit has been improperly adjusted beyond recognition. If the table value operating point isn't acceptable, refer to the detailed description. If this happens, just follow the instructions in the 'Power Adjustment' section.

Start — This switch has two uses to find a new operating point.

1. An **extended tuning sweep** is conducted if pushed for 2 - 4 seconds AND J5 is installed, to eliminate the possibility of tuning aliases. In other words, it allows the user to force an extended tuning adjustment and witness the results as a troubleshooting tool if needed. This type of operation also occurs automatically, but the user would be unaware of it. If either the power or current is different than the values found in the 'Power Level Table' below, store the new value by removing J5, adjusting the voltage pot (per 'Power Adjustment'), store the corrected running value (per above 'Op_OK'), and re-install J5.
Once the inverter finds resonance as its operating point, normally it makes only minor adjustments to compensate for minor pressure and flow changes.
2. A sensitive **manual power adjustment** by using the internal voltage control AND J5 is removed will be available if the 'START' switch is pressed for 2 – 4 seconds. While this same function can be performed without pressing the 'START' button, this mode converts the High/Low LEDs into a sensitive meter which is centered around the stored value of the programmed power table in the processors' memory. In other words, you can reset the power level with extreme accuracy to the previous or factory value, without an amp meter.

This feature is particularly useful if the technician finds the inverter grossly misadjusted and there is no voltmeter available. To return to the past operating point, remove J5 and press 'START' for 2 to 4 seconds. The HS TEMP LED will wink to ignore faults and tell the technician to manually adjust the voltage (J9 IN). Use the HIGH and LOW LEDs to adjust the full power with the voltage. When the LEDs are both off, the correct power is reached. The 'START' feature will time out after two minutes. The technician can press 'START' again.

Turn the inverter off. Replace J5 and restart. The 'LOCKED' LED will flash signifying the inverter is operating normally.

There is more detail on these features at the back of this manual.

METHODS OF ON – OFF CONTROL JUMPER BLOCK CONFIGURATION AND FUNCTION

SPDT RELAY OR SWITCH

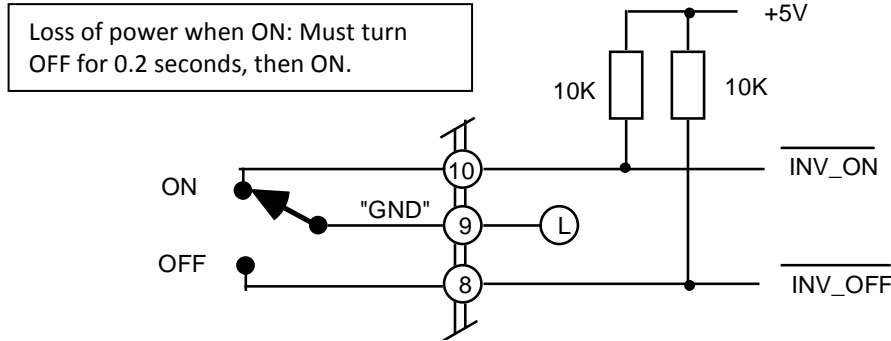

FUNCTION	PWR_UP	J1	J2	J3
To start the inverter the switch must first be in the OFF position, then moved to the ON position for ozone to start.	OMIT	OMIT	X	X
To start the inverter the switch must first be in the ON position, then power is applied to produce ozone. The inverter will start after the "LED banner flash".	IN	OMIT	X	X
X = Don't care condition.				

ON – OFF PUSHBUTTONS

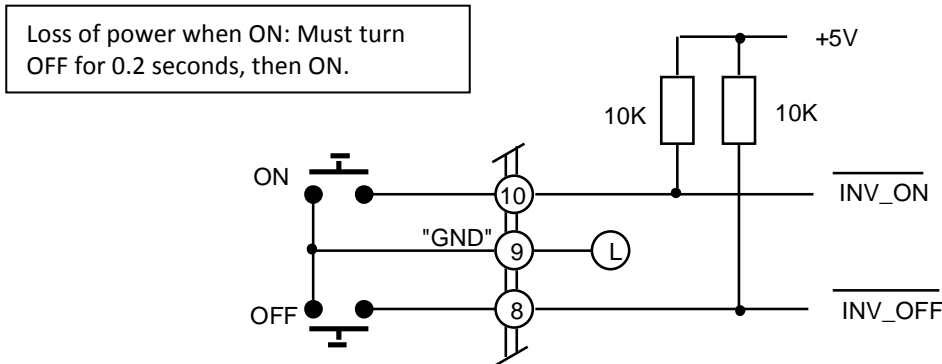

JUMPER BLOCK CONFIGURATION AND FUNCTION

FUNCTION	PWR_UP	J1	J2	J3
Push ON and push OFF to start ozone production. If both pushbuttons are actuated simultaneously, the inverter will stay OFF.	X	OMIT	X	X
X = Don't care condition.				

SAFETY SWITCH INVERTER CONTROL CIRCUITS

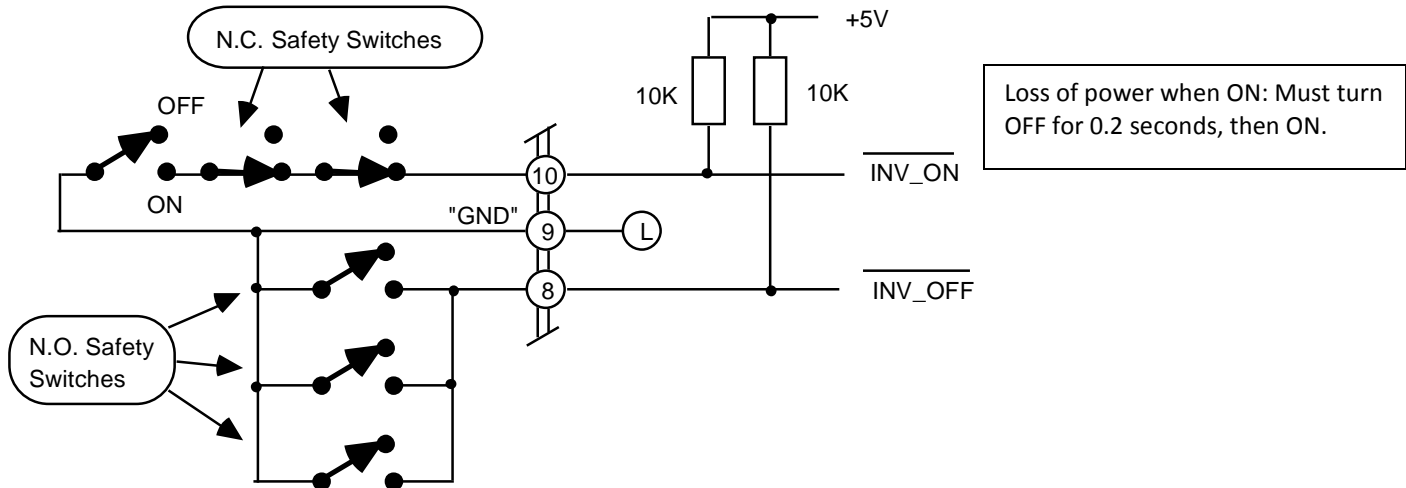

FUNCTION	PWR_UP	J1	J2	J3
To start the inverter the switch must first be in the OFF position, then moved to the ON position for ozone to start.	OMIT	IN	OMIT	X
To start the inverter the switch must first be in the ON position, then power is applied to produce ozone. The inverter will start after the "LED banner flash".	IN	IN	OMIT	X
X = Don't care condition.				
If any of the normally open (N.O.) safety switches goes closed then ozone production cannot start or will cease if operating.				

PLC POWERED SAFETY SWITCHES WITH STATUS REPORTING

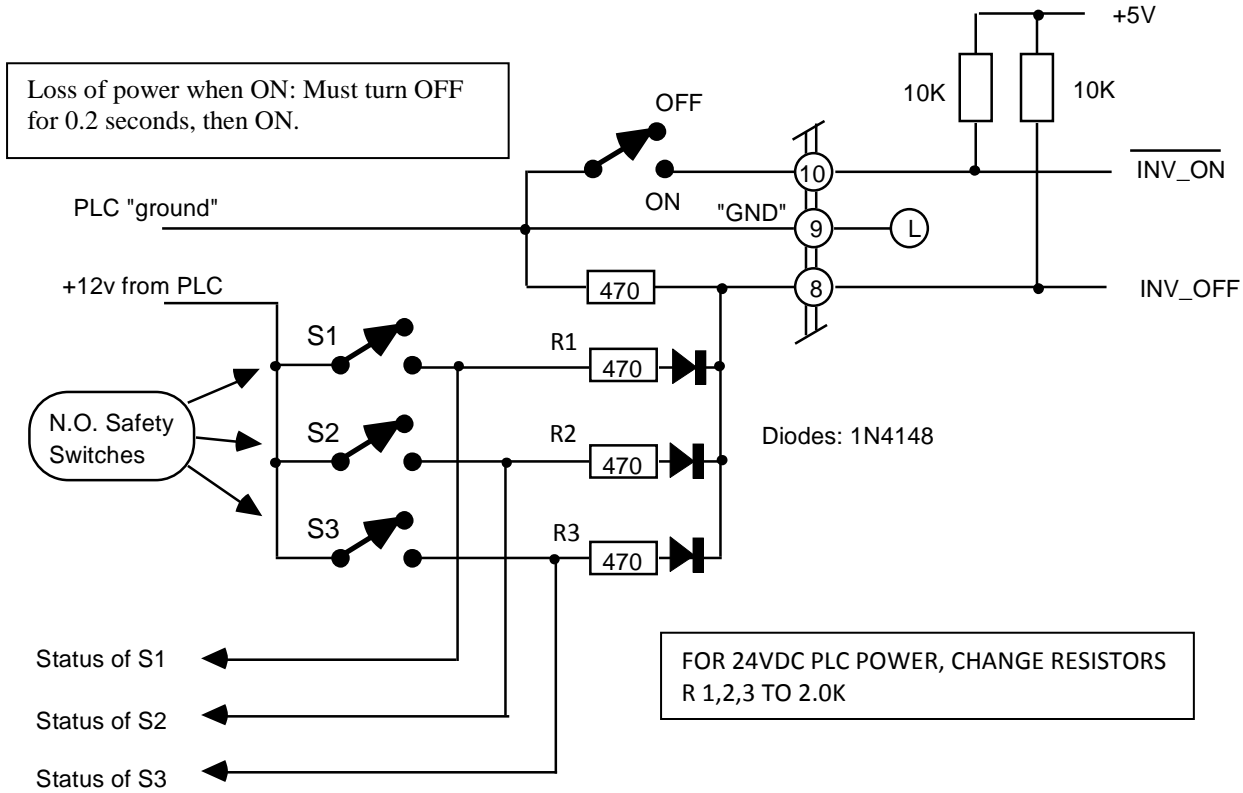

FUNCTION	PWR_UP	J1	J2	J3
To start the inverter the switch must first be in the OFF position, then moved to the ON position for ozone to start.	OMIT	IN	IN	X
To start the inverter the switch must first be in the ON position, then power is applied to produce ozone. The inverter will start after the "LED banner flash".	IN	IN	IN	X
X = Don't care condition.				
If any of the normally open (N.O.) safety switches goes closed then ozone production cannot start or will cease if operating. This circuit allows the PLC to monitor the switch status.				

Note: The processor scans J1, J2, J3 only on power up. Changing the jumpers will not be immediately recognized unless the inverter is shut OFF – then ON.

5.5 Two user wiring options are shown. If an Auto/Manual front panel switch is desired to control one or two inverters, use the schematic shown. This also allows a single control input to control both inverters with either inverter powered down.

4 - 20 MA. AUTO/MANUAL TRANSFER SWITCH CONTROL LOOP FOR TWO INVERTERS

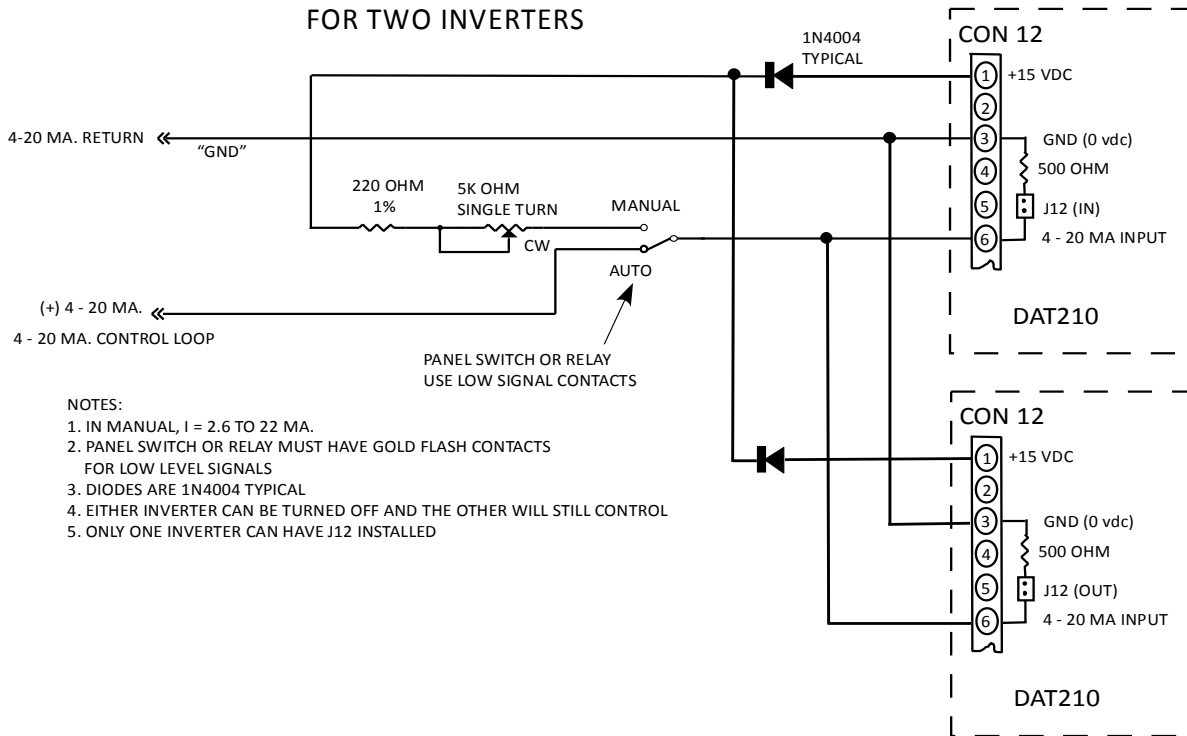

0 - 10 VDC AUTO/MANUAL TRANSFER SWITCH CONTROL LOOP FOR TWO INVERTERS

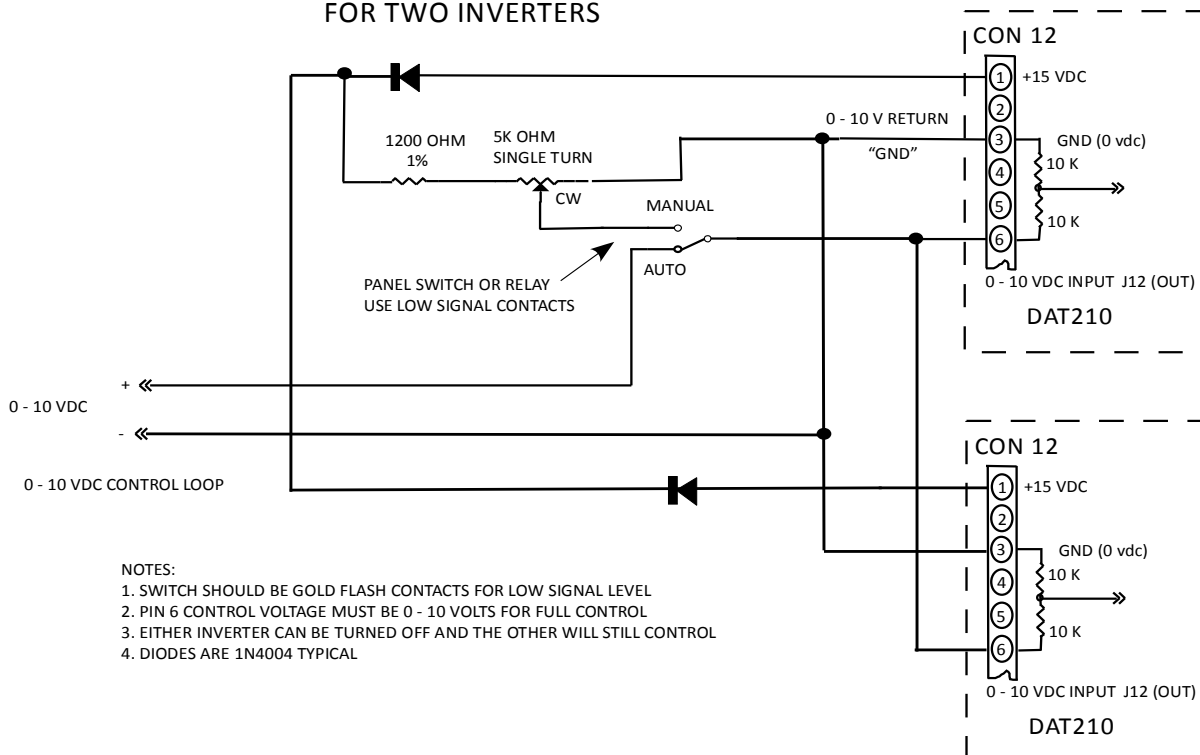

Section 6. Operating Condition LEDs

DAT210 Status LED description

- +5vdc** Low voltage DC supplies are operational (line voltage applied to unit).
- INV ON** **On solid** – Inverter output enabled. Ozone output per PDM command, if enabled.
Flash - Output enabled via ON command but disabled by PDM < 2ma (4/20). Output is re-enabled if PDM > 3ma, 'INV ON' LED on solid.
- LOCKED** **OFF, Winks ON** – Semi-Automatic tuning is enabled when jumper J5 is removed. Frequency tuning occurs during wink interval. Search rate varies automatically. The Voltage pot is active and should be used to set the desired full power operating level. See: 'Start' button adjustment procedure.
ON, Winks OFF – Occurs only in 'Auto-Tune mode when Jumper J5 is installed and signals that the proper operating point has been established and 'locked'. The indicator is ON mostly continuously, and only winks off momentarily while a new scan of the operating parameters is validated.
- LOW POWER** **Flash** – Output current is slightly below the programmed tolerance window. A service request enunciation is placed via the soft fault if switch S5 is ON. No disabling action is taken in this state. If the current continues to drop, the flash will transition to an on steady (solid) mode – see ON solid, below.
Note: It is normal for the LOW POWER LED to flash for a few seconds when a large incremental increase in PDM is commanded. This can be helpful in that it will provide a visual indication that the PDM control input is being stimulated. No enunciation action is taken.
ON solid – Output current to the ozone cell is lower than the allowable programmed window. If sustained, a hard fault will be generated in 32 seconds, which disables ozone production when FAULTED LED is ON solid. This LED will be latched on indefinitely to provide service diagnostics. The latched fault is cleared by either an OFF / ON transition (includes 4/20 off as well) or power cycle.
- HIGH POWER** **Flash** – Output current is slightly above the programmed tolerance window. A service request enunciation is placed via the soft fault if switch S5 is ON. No disabling action is taken in this state. If the current continues to increase, the flash will transition to an on steady (solid) mode – see ON solid, below.
Note: It is normal for the LOW POWER LED to flash for a few seconds when a large incremental decrease in PDM is commanded. This can be helpful in that it will provide a visual indication that the PDM control input is being stimulated. No enunciation action is taken.

ON solid – Output current to the ozone cell is higher than the allowable programmed window. If sustained, a hard fault will be generated in 32 seconds, which disables ozone production when FAULTED LED is ON solid. This LED will be latched on indefinitely to provide service diagnostics. The latched fault is cleared by either an OFF / ON transition (includes 4/20 off as well) or power cycle.

■ LOAD FAULT

ON solid – Possible flooded cell, shorted cell or open transformer connection.

■ HOT LOAD

Wink – Cell temperature is slightly above programmed limit. No disabling action is taken in this state. If the temperature continues to increase, the wink will transition to a flash (longer duty cycle than wink) – see below. During this mode the processor is reducing the PDM level automatically in an effort to lower the cell temperature. This of course also reduces ozone output.

Flash – Cell temperature continues to rise. PDM is controlling power to hold cell temperature constant in an effort to produce some ozone and remain online. This elevated temperature will not damage the cell. A service request enunciation is placed via the soft fault if switch S5 is ON. No disabling action is taken in this state. If the temperature continues to rise, the flash will transition to an on steady (solid) mode – see ON solid, below.

ON solid – The ozone cell temperature is higher than the allowable programmed window. If sustained, a hard fault will be generated in 32 seconds, which disables ozone production when FAULTED LED is ON solid. This LED will be latched on indefinitely to provide service diagnostics. The latched fault is cleared by either an OFF / ON transition (includes 4/20 off as well) or a power cycle.

■ HS TEMP

Wink – Heat sink temperature (electronics) is slightly above programmed limit. No disabling action is taken in this state. If the temperature continues to increase, the wink will transition to a flash (longer duty cycle than wink) – see below. During this mode the processor is reducing the PDM level automatically in an effort to lower the heat sink temperature. This, of course, also reduces ozone output.

Flash – Heat sink temperature continues to rise. PDM is controlling power to hold cell temperature constant in an effort to produce some ozone and remain on line. This elevated temperature will not damage the cell. A service request enunciation is placed via the soft fault if jumper J4 is in place. No disabling action is taken in this state. If the temperature continues to rise, the flash will transition to an on, steady (solid) mode – see ON solid, below.

ON solid – The heat sink temperature is higher than the allowable programmed window. If sustained, a hard fault will be generated in 32 seconds, which disables ozone production when FAULTED LED is ON solid. This LED will be latched on indefinitely to provide service diagnostics. The latched fault is cleared by either an OFF / ON transition (includes 4/20 off as well) or power cycle.

■ IGBT FAULTED If a short circuit is present on the inverter output, sophisticated electronic circuits instantly disable the effected power section. If this occurs over too many cycles, the output is disabled and a fault is enunciated.

■ FAULTED **Rapid Flash** – signals a **SOFT FAULT** via open collector to terminal #11. **Switch S5 must be ON for this mode to be active.** A soft fault up to 32 seconds in length can be produced by any one of the following: cell operational current signature, high or low current, high instantaneous current in the output power section, over temp in the electronics or cell. A hard fault will **not** be latched or reported as a hard fault if the fault self-corrects within 32 seconds.

Both cell and electronics over temp conditions invoke an automatic closed loop turndown control of the PDM function that results in a constant, but elevated, cell temp. This condition can be sustained indefinitely. If the system can manage the event, no hard fault is delivered. **This is a summons for service.** Ozone production is reduced, but not disabled.

On solid - signals a **HARD FAULT** via terminal #11 (pulls low). Ozone production is OFF; the nature of the fault is latched and enunciated.

Section 7 Applications

7.1

The DAT210 is intended to be used with PTI transformers and inductors to drive the user's ozone cell. PTI ozone cells are well matched to the DAT210's performance but others can be used. Since the user's cells can have widely differing gaps, lengths and materials of construction, the inverter should be put in MANUAL mode to allow the user to find their cell's operating area.

Suggested installation wiring for an ozone application:

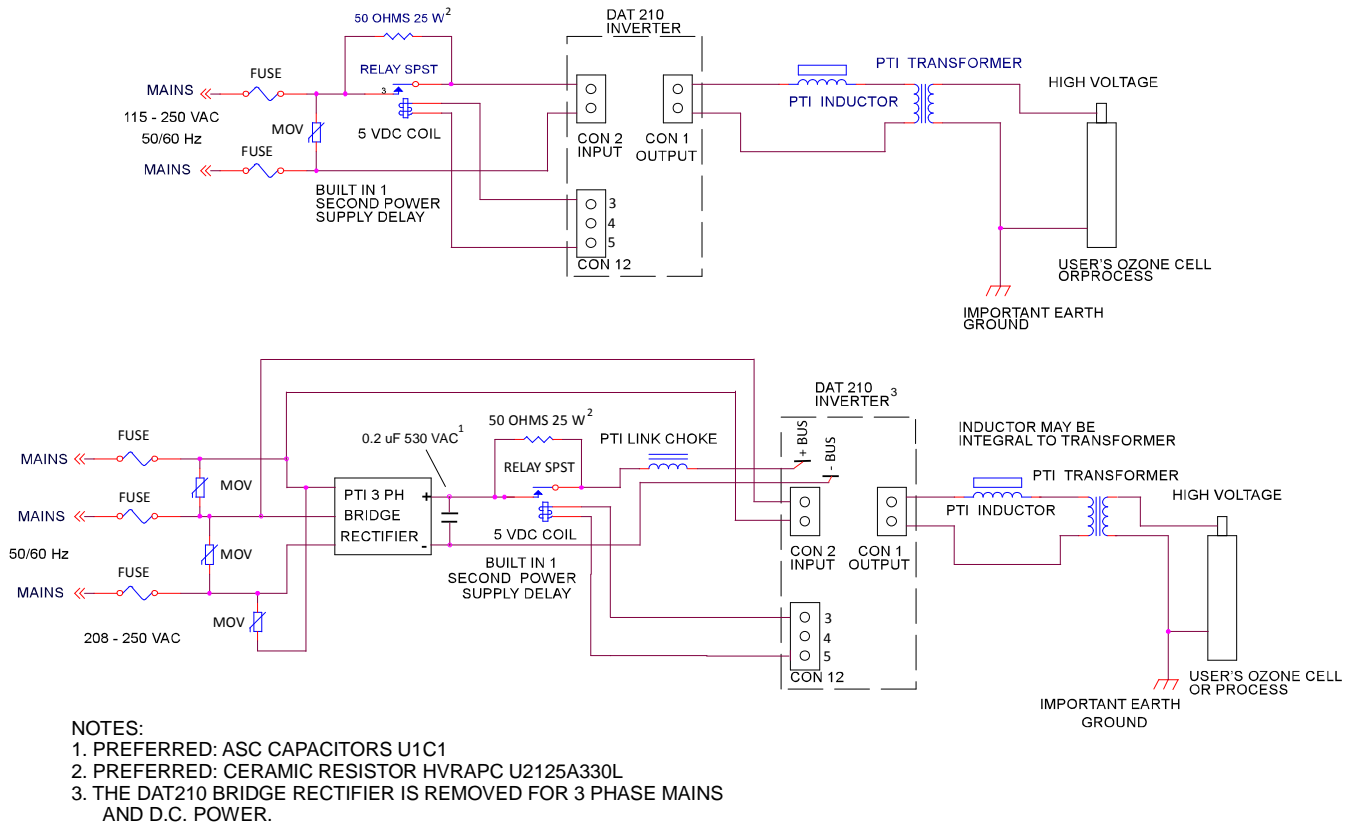

Figure 7.1

7.2

Figure 7.2 is a preconfigured and wired inverter assembly that includes the parts left of the resonating inductor on the 3 phase circuit.

Features and benefits include:

- Soft start circuit to extend the life of the filter capacitors
- Power factor correction to 0.95
- Assembly cost reduction

Specify P/N 70250 that includes these components. The DAT210 is priced separately. A DAT210 is used in place of a DAT213 with the 70250 assembly.

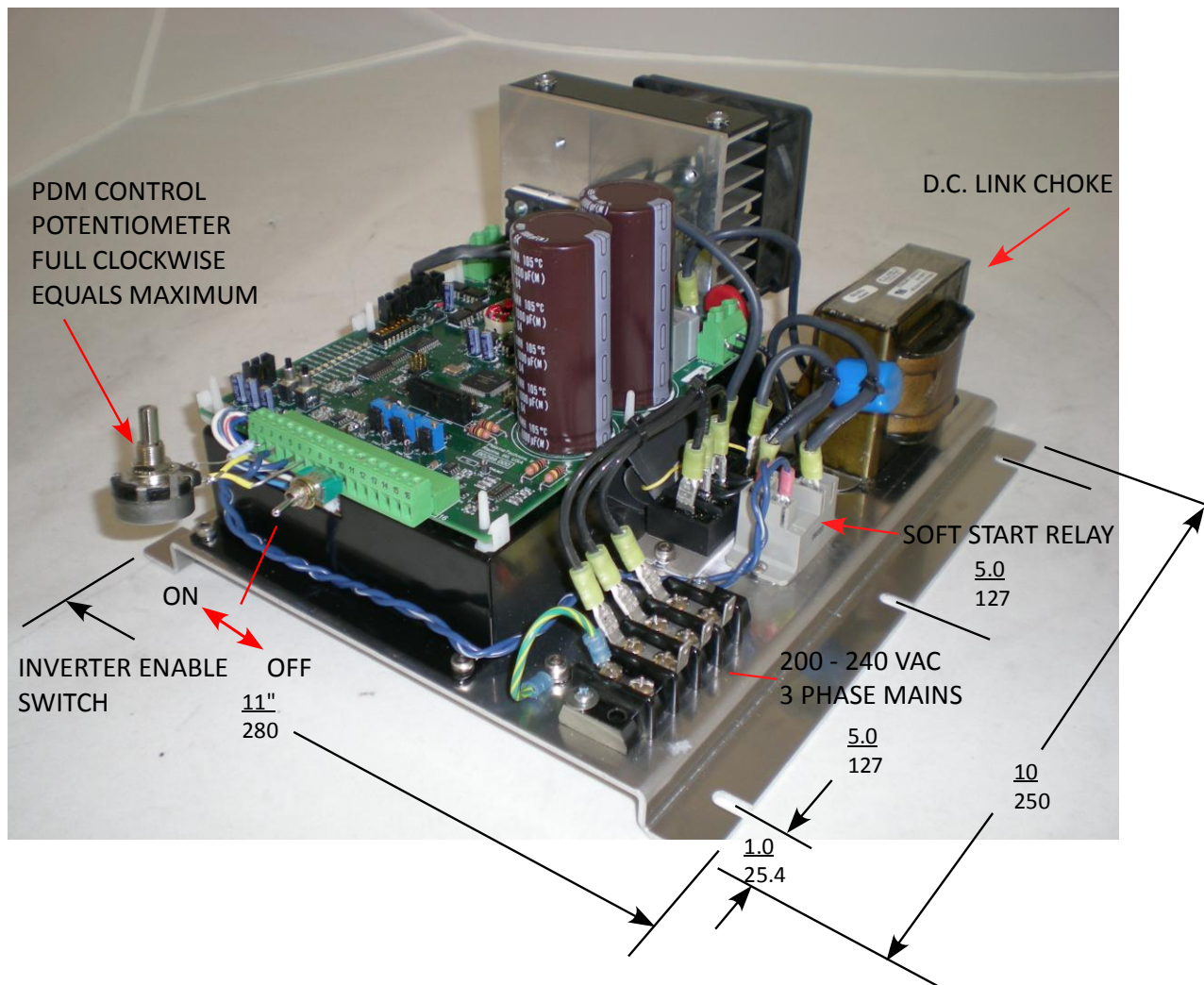

Figure 7.2

7.3

PTI has several transformer types that can be used with the DAT210:

The 55-HLHxx102/D115, for example, is rated for 120v or 240v operation, 1KVA at 1.2 KHz. While this transformer can be operated at 600 Hz one must be very careful to reduce the input voltage in half so as to prevent overheating and burn out. This reduction will also reduce the power available for said transformer to 600 VA. Increasing the frequency above 1.2 KHz is no problem either as long as the case temp limits are observed.

The HSH series transformers will operate from 5 to 10 KHz.. This transformer can easily be driven to power levels beyond its means by the inverter. The HSH series is used with a matching choke to form a tuned circuit, which are intrinsically self-protecting for mis-tuning.

The same general rules also apply to the 100-HLHxx302/D230, which is rated at 3kva at 1.2khz. It has a primary of either 230 or 460v. This transformer is a better match for the capacity of the DAT 210.

PTI has several voltage output levels available in the 3kva Case100 series. If you are uncertain as to the proper high voltage level needed in your application it is recommended that the transformer be strapped for 460 V operation while the inverter has 230 applied. This will reduce the output high voltage by 50%. I.E. A 10kv transformer would produce 5kv and is also de-rated in power from 3 KVA to 1.5 KVA. The need for this test configuration is mandated by the measurement of rated or nearly rated inverter input current while having a relatively low transformer primary voltage measurement, 100-140 V (240 Vac inverter input).

It is recommended to contact PTI before attempting to match a transformer to a load. PTI experience can solve application problems before the problem becomes more critical.

Section 8 Start up

8.1 Safety Considerations

DANGEROUS VOLTAGES ARE ON THIS CIRCUIT BOARD

To avoid injury to personnel and/or damage to equipment only qualified personnel should perform the procedures outlined in this chapter. This person must understand both the electrical and mechanical components associated with the application.

Thoroughly read and understand the following procedures before beginning the start-up process. The following specific safety procedures must be observed when performing any maintenance or adjustments on the amplifier.

Always turn off and lock out AC power at the main machine disconnects switch. Do this before touching any electrical or mechanical components.

High voltage may be present even with all electrical power supplies disconnected.

Use an appropriate meter to verify that all DC bus capacitor banks have been discharged before working on any equipment. Do not rely exclusively on high voltage RED LED indicator for bus voltage, as dangerous voltage levels may remain even when the indicator is off.

Follow industry recognized safety procedures. Use only one hand to hold test equipment probes, wear approved eye protection, etc. Before energizing the inverter, make sure that device(s) connected to the output of the inverter will not result in injury or damage to equipment. Keep unnecessary personnel out of the immediate work area. Never leave an inverter cabinet open and unattended.

8.2 Start-up Checklist

To ensure a complete checkout and test, check off each step as it is completed. If the proper event does not occur while performing this start-up procedure, do not continue. Take the appropriate action to correct the malfunction before proceeding.

- Ensure the main disconnect switch is locked off. High voltage may be present even with all electrical power supplies are disconnected. Use an appropriate meter to verify that all DC bus capacitor banks have been discharged before working on any equipment. Do not rely exclusively on RED LED indicator of bus voltage, as dangerous voltage levels may remain even when indicator is off.
- Verify that the inverter mounting has been performed in accordance with the guidelines listed in
- Chapter 2.
- Inspect the inverter to verify that all optional modules have been selected and installed according to
- the system drawings and documentation.

- Verify that all wiring has been installed according to the wiring plan produced by the design engineer and according to the guidelines listed in Chapter 3 for proper connection, grounding, wire size, labeling, routing and applicable codes. The DAT 210 does not have internal fusing. Install input and output (optional) fusing per suggestions Page 23.
- Verify that all electrical terminals, screws, nuts, and bolts are securely fastened.
- Apply high voltage DC or single-phase AC power to the inverter as specified.
- Check to make sure that the RED Bus voltage LED is on, indicating bus voltage.

8.3 Start-Up Procedure Power Adjustment

Reasons for changing the factory setup:

By altering the 'Voltage' setting, you can easily modify the full power operational point if need be. Remember that the purpose of the PDM control is to provide a turndown from the 100% power set-point established by the **VOLTAGE** pot. The goals are 1) Maximum power and 2) Current High/Low limits. Adjustment is very easy.

If it is determined that the Plasma Block® has much more ozone output than the application requires. You would know this if, for example, if the closed loop control from an ORP unit always had the PDM adjusted to a very low value of current, like 6-10ma. **(Use Method 1)**

OR

A PlasmaBlock® is going to be applied at pressure and flow range that is different from the factory setup. **(Use Method 1)**

OR

If the inverter was purchased to be used with a PTI resonating inductor and transformer set to drive a new cell or changed cell configuration, the inverter would have to be tuned. **(Use Method 2)**

Method 1 for PTI cells and PlasmaBlocks®

REMOVE POWER FROM THE INVERTER FOR SET UP

1. **Install a true RMS current clamp-on meter** to one of the mains AC power wires, terminals 1 or 2 of Connector 2. A power meter could also be used.
Note: An inexpensive and surprisingly accurate power meter can be purchased for \$25-\$35: UPM model EM100 or Kill-A-Watt from P3 International.
2. **PDM should be set at 100%**. Another method of turning the PDM to full ON if it is more convenient is to turn **Switch S1** OFF. This forces the PDM at 100%.
3. **Verify Switch S4 and S5 OFF**: fault enable. This will prevent any faults, current exceeding the High/Low limits for example, from shutting down the unit while it's being adjusted.
Note: Maximum power safety is now OFF. It is possible to damage the ozone cell.
4. **Pull jumper J5 AUTO**, which will select the **Semi-Auto** mode and allow the **VOLTAGE** pot (potentiometer) to be manual active. The frequency will still be automatically adjusted for resonance.
5. **Turn the VOLTAGE pot counterclockwise (CCW)** until clicking sound indicates minimum.

APPLY POWER TO THE INVERTER – TURN THE INVERTER ON

6. **Adjust the VOLTAGE pot CW** to the desired maximum current (power) level permissible. Ozone levels alone can also be used to establish maximum power if satisfactory at a lower current (power). The processor continues to optimize other aspects of the tuning process as indicated by the occasional 'wink' of the **LOCKED** (resonant frequency found) LED. If the **VOLTAGE** control is increased excessively (pot CW), and a safety limit is reached, the pair of Red LEDs will **flash rapidly** in an alternating manor.

This will not damage the ozone cell. Simply **reduce** (CCW) the voltage **control** to an acceptable level of current (power) and the LEDs will extinguish.

7. **Set the High/Low power limits.**

Push the **OP_OK** push switch once (1 to 5 seconds). Two Yellow LEDs will come on and blink slowly. This is the +/- 40% power fault tolerance limits.

Push **OP_OK** once again. The Yellow LEDs will flash faster. This is the +/- 20% limit.

Push **OP_OK** once again. The Yellow LED will flash even faster. This is the +/- 10% limit.

Keep pushing **OP_OK** and the cycle repeats.

The normal factory recommended limit is +/- 20% (40% total).

8. Lock in the new operating point by **pushing and hold the 'Op_OK' button until the Red LEDs come ON.** Then release it. Then ALL the LEDs will come ON (except FAULT) momentarily to acknowledge your input and the inverter will turn OFF. This action permanently stores the new parameters in the processors memory and causes a reboot of the unit.
9. Set Switches **S1, S4** and **S5** to ON. Reinstall **J5** (AUTO_Tune). Re-enable by cycling the inverter OFF and ON.
10. Now observe the inverter gradually increase power to the new programmed level automatically at 100% PDM. Frequency control is automatic and the **LOCKED** LED will cycle indicating frequency lock. The inverter PDM can now control power from 1% to the 100% new programmed value.

You should now observe that the PDM level (power control) being commanded from the ORP unit is much greater, for example, hence making the control loop more stable.

OR

The inverter is now properly configured for the new ozone cell components

OR

The inverter is now properly configured for new pressure or flow ranges.

Method 2 For other manufacturer's generator cells or other applications

Make sure the inverter has the correct code for the frequency range of interest. Either the factory has or will set this up before shipment or you will need a PC in terminal mode connected via USB to RS-232 to the inverter board. Call the factory for the correct codes and instructions.

Monitor the line current with a true RMS ammeter. The following assumes power factor correcting components are installed. See the 700250 inverter assembly.

It will be necessary to configure the inverter for a manual mode of operation.

S1 OFF Forces PDM to 100% maximum for tuning purposes

S5 OFF Disables alarms and power limits. **It is possible to apply too much power.**

Jumper J3 IN Enables Manual operation of frequency and voltage

Jumper J5 OUT Disables full Auto-Tune

Turn the FREQUENCY pot full clockwise until clicking sound is heard

Turn the Voltage pot full counterclockwise (minimum) until clicking sound is heard then CW 3 turns

Procedure:

1. Observe the current or power meter and reduce the frequency by turning the Frequency pot CCW. The power will peak at a lower power because the Voltage pot is turned down.

- If the frequency is lowered too far (CCW) the power will reduce. You want the peak.
2. Increase the voltage at the current (power) peak until ½ of the maximum desired current per leg (power) is reached.
 3. Readjust the frequency slightly to find the current peak.
 4. Increase the voltage until the current reaches 90% of the expected maximum power.
 5. Verify the frequency is still at peak with the frequency pot.
 6. Increase the voltage pot CW to reach 100% expected power.
 7. Set the High/Low power limits.
 - Push the **OP_OK** push switch once (1 to 5 seconds). Two Yellow LEDs will come on and blink slowly. This is the +/- 40% power fault tolerance limits.
 - Push **OP_OK** once again. The Yellow LEDs will flash faster. This is the +/- 20% limit.
 - Push **OP_OK** once again. The Yellow LED will flash even faster. This is the +/- 10% limit.
 - Keep pushing **OP_OK** and the cycle repeats.
 - The normal factory recommended limit is +/- 20% (40% total).
 8. Lock in the new operating point by **pushing and hold the 'Op_OK' button until the Red LEDs come ON**. Then release it. Then ALL the LEDs will come ON (except FAULT) momentarily to acknowledge your input and the inverter will turn OFF. This action permanently stores the new parameters in the processors memory and causes a reboot of the unit.
 9. Set Switches **S1, S4** and **S5** to ON. Reinstall **J5** (AUTO_Tune). Re-enable by cycling the inverter OFF and ON.
 10. Now observe the inverter gradually increase power to the new programmed level automatically at 100% PDM. Frequency control is automatic and the **LOCKED** LED will cycle indicating frequency lock. The inverter PDM can now control power from 1% to the 100% new programmed value.

If during the manual portion of the tuning effort it is not possible to reach the current peak, call the factory to help diagnose the reason. It may be that the load is very insensitive to the frequency and that Auto-Tune is not feasible. In that case, expect the inverter to be left in the manual mode.

Section 9

TROUBLESHOOTING

PROBLEM	STEP	VERIFY	NEXT STEP
ON - OFF switch/PLC control - nothing happens	1	Is there power to the inverter?	No - troubleshoot elsewhere. Yes - Get a voltmeter and do Step 2
	2	Was there 5 seconds between applying power and the ON command?	No - increase the timing between application of power and the ON command. See Section 6 p.18 & 19. Yes - Step 3
	3	+5 VDC between Terminals 5(+) and 3 on CON12 and +5 green LED ON?	No - Check connector seating, broken wires to the small power supply inside the generator toward the rear. Replace supply if necessary. Yes - There is power to the inverter. Step 4.
	4	Is the "INV ON" light on? Measure voltage terminals 3 & 5 Connector 12. Verify if the external command output power setting is at zero? Verify 4/20 or 0 - 10 VDC control as set by Switch 8 on the inverter board.	No - Step 5 Yes - Increase the ozone output control voltage/current.
	5	If you have gone through steps 1 - 4 without results, it is possible that the inverter board has failed.	Replace the inverter circuit board. Refer to the instruction sent with the replacement to ensure reliable operation.

FAULT indicators on the circuit board are illuminated.

ALL LEDS flashing	1	Low voltage power supply cycling on and off	Problem with a broken wire, mis-wiring or shorted circuits in the inverter electronics. Look for metal drilling chips caused by contractor drilling. If there, vacuum the electronics thoroughly and retry. If this is not the problem, go to 2.
	2	If there are no other shorts in the system or the system is mis-wired, the low voltage power supply may be defective.	Replace the low voltage power supply.
FAULTED light - Flashing = soft fault temporary condition	1	Caused by: High or Low cell current, high instantaneous current in power section, over temperature in the electronics or cell.	Usually this fault is a result of improper tuning of the inverter beyond factory limits. Go to Step 2
	2	Is the ambient temperature greater than 40 C (104 F)?	Yes - Improve ambient air flow. Inverter will eventually compensate by running at reduced power. No - Go to Step 3
	3	Retune the inverter using the procedure in Section 7. Review Section 4.	This should solve the problem if flashing. Flashing is a "call for service" with reduced ozone output.
FAULTED light - On solid = Hard fault condition and the inverter is locked OFF	1	Look at other fault lights to diagnose the problem. Ozone production is turned OFF.	Go to step 2.

IGBT FAULTED	2	Is IGBT faulted light ON?	Yes - There is a short in the inverter output section that has exceeded the allowable event limit. Look for damaged or loose wires, metal chips, water corrosion or anything that could cause a short. No - Go to step 3
HS TEMP	3	Is HS TEMP faulted light ON?	Yes - Review Status LED description for detail No - Go to Step 4
HOT LOAD	4	Is HOT LOAD faulted light ON	Yes - Review Status LED description Section 6 for detail. No - Go to Step 5
LOAD FAULT	5	Is LOAD FAULT light ON?	Yes - Possible water flooded cell due to the process entering the cell. If the process water is clean, empty the water out of the cell and flush with DI water or 91% alcohol. EMPTY FLUSH WATER FROM CELL! Then dry with very dry oil free air or oxygen for several minutes. Try to operate again. Do not disassemble the cell. Call the factory. No - Go to Step 6.
HIGH POWER	6	Is HIGH POWER light ON?	Yes - Review Status LED description Section 6 for detail.
LOW POWER	1	Is LOW POWER flashing?	Yes - This is non-critical indication that the power is less than the programmed window. No - Go to Step 2
	2	Is LOW POWER ON steady?	Yes - Output current is too low than the programmed window. If this condition remains for more than 32 seconds, a hard fault will shut off ozone and turn on the fault LEDs for diagnostics. Review Status LED description in Section 7 for more detail.

Section 10

NOTES & GENERAL INFORMATION

Enhanced product features include

1. **Soft and Hard fault reporting.** **Soft fault** will signal that attention is required. The system is still functional; perhaps at a reduced ozone output level. A **Hard Fault** is signaled when the Plasma Block® has disabled itself. In both cases fault LED's will continue to display the problem until serviced. Reset is accomplished simply by an OFF followed by an ON command.
2. **Constant temperature mode.** If for some reason the cell or electronics cooling is compromised, the processor will reduce PDM automatically to maintain a functionally high cell temperature, all the while generating a Soft Fault. This limp along mode will be at reduced ozone levels.
3. Optionally selectable **High / Low current** fault reporting. This enables a latched fault if the cell current excursion is beyond a normal operational window. PDM level has no effect on enunciation. The tolerance window is easily field set to one of three levels.
4. **Easy troubleshooting.** Extensive fault reporting and fault latching, even if the output is stopped by the user or internal stop, preserves the fault condition indefinitely as long as AC power is applied.
5. **Longer fan life.** Fan speed unaffected by line voltage changes, and is temperature and time controlled. When ozone is commanded off the fan cools down the cell and turns off automatically, thereby **saving energy and extending fan life.**
6. PDM start up ramp rate is automatically controlled by cell temperature to reduce the chance of inadvertent thermal shock under extreme cold temperature conditions.
7. Extended PDM control methods include: 0 – 10vdc via Pot or PLC, 0 / 20ma, 4 / 20ma (with OFF below 2ma). All PDM modes utilize dynamic slew rate limiting for smooth and stable control.
8. 0 – 5vdc analog output for **bus current** and **bus voltage** enables simple PLC monitoring of real power without expensive CT's and complex interfaces.
9. Plasma Block® will **engage when AC power is applied** if continuous ON command is present one of the options described in Section 5.4 (Page 16), thereby simplifying restart in simple, controlled environments.
10. All established operational parameters are **permanently saved in memory** even if power is removed. **No backup power or batteries** are used. Future firmware will likely include histograms of important performance data. On board RS232 interface, for future direct computer data interface.
11. Power on LED marquee verifies LED operation and displays **firmware revision level.**
12. Operating firmware is fully **encrypted** and field **upgradable.**

Section 11. Warranty

PTI Electronic Transformer / Inverter Limited Warranty

The PTI Electronic Transformer / Inverter is warranted by Plasma Technics, Inc.[®], to the original purchaser to be free from defects in material and workmanship under normal use and service for a period of **ONE (1) year** from the date of purchase under the following terms and conditions:

The obligation of Plasma Technics, Inc.[®] is expressly limited to repairing or replacing, at the option of Plasma Technics, Inc.[®], any PTI Electronic Transformer / Inverter returned to it during the warranty period, which is determined by PTI to be defective in material or workmanship.

Any improper use /operation or installation other than in accordance with the published application materials, instructions and specifications established by Plasma Technics, Inc.[®] shall void this warranty.

The obligation of Plasma Technics, Inc.[®] Shall not include any transportation charges, costs of removal or installation, labor charges or any direct, indirect, consequential or delay damages.

Attachment or use of components or accessories not compatible with the PTI Electronic Transformer / Inverter shall void this warranty.

Any alteration not authorized by Plasma Technics, Inc.[®] in writing, accident, misuse, abuse or damage to the PTI Electronic Transformer / Inverter shall void this warranty.

The electronic transformer / inverter subject to this warranty is not warranted as suitable for any particular purpose or use of the purchaser. The suitability of any PTI Electronic Transformer / Inverter for any purpose particular to the purchaser is for the purchaser in the purchaser's sole judgment, to determine. Plasma Technics, Inc.[®] assumes no responsibility for the selection or furnishing of a transformer suitable to the purchaser's needs or the purposes of any particular purchaser.

This warranty is in lieu of any other warranty express or implied, including specifically but without limitation warranties of merchantability or efficacy and of all other obligations or liabilities in connection with the sale or use of the PTI Electronic Transformer / Inverter.