



INSTALLATION & OPERATION MANUAL Plasma Blo₃ck



Appnote PBA-45g V2b

TABLE OF CONTENTS

	PAGE	
TABLE OF CONTENTS	2	
FEATURE LIST	3	
INSTALLATION AND OPERATION OF PLASMA BLO₃CK[®] COMPLETE ASSEMBLIES INVERTER AND CELL		
SECTION 1	GENERAL INSTALLATION MOUNTING REQUIREMENT AND ENVIRONMENT	4
SECTION 2	GENERAL WIRING PRACTICES	5
SECTION 3	GENERAL OPERATING CONSIDERATIONS	6
SECTION 4	CHANGING THE FACTORY POWER CONFIGURATION	8
SECTION 5	PERFORMANCE GRAPHS	10
SECTION 6	MECHANICAL LAYOUT	11

PLEASE REFER TO THE **DAT 210** OR **SSD 110** MANUALS FOR INVERTER SPECIFIC INSTALLATION AND OPERATIONAL DETAILS.
REFER TO THE **PLASMA BLOCK[®]** APPLICATION GUIDE FOR INSTALLATION TIPS.

50g/hr Plasma Blo₃ck[®] (Air-cooled)



- **Silent, Rugged, Reliable**, Cost-effective, **Compact** and Light Weight, Ceramic, **Air-cooled** and power-Efficient.
- **25 gr/hr (1.3 lbs/day) at 8%** and 3 LPM : 45 g/hr (2.4 lbs/day) at 5% weight and 10 LPM (Oxygen or Concentrator) at 440 watts.
- **No exposed, high-voltage safety hazards.**
- **Precise ozone control using Pulse Density Modulation** (PDM) via potentiometer, 4/20 ma or 0-10 VDC.
- **Precise Control with Turn-down to 1%.**
- **Useful pressure range: 5 – 100 psi. Pressure as tested 10 psi (0.68 bar)**

Design Features:

- All high voltage is safely contained completely within the Plasma Blo₃ck[®] thereby eliminating shock hazards and dirt build up which can cause dangerous flash over. High voltage wiring is booted and all metal grounded. Directly installable by UL 508a panel house.
- Pre-mounted, seasoned and tested package sub-system, which includes cell, transformer, inverter and fan. Design uses the finest high quality material for maximum performance and efficiency.
- Advanced design eliminates the possibility of ozone leakage from the body or fittings. The only leak possible is at the customer tightened ozone fitting.
- **Micro gap** design results in high concentration, reduced high voltage levels and more efficient operation. **Requires concentrator or bottle feed of at least -60°F dew point, filtered, positive pressure oxygen.** Materials in the gap are: **ceramic and aluminum.**
- Precision machined aluminum block eliminates inefficient hot spots and facilitates operation at **pressure, vacuum and atmospheric.** Only 2 psi drop with 10 LPM. Flow. As with any cell, the most predictable performance occurs in the positive pressure domain.. Maximum pressure 100 psi.
- Ozone level automatically controlled to ± 1% from 85 to 130 vac; or 170 v to 260 vac depending on model.
- The Inverter is a reduced power version of PTT's popular DAT210. All control and interface features of the DAT210 are available in this product.
- **23 kHz** operating frequency for **silent** operation. Inverter is capable of driving 2 cells, for easy scaling.
- Line voltage 120v or 240v, 50/60hz.
- Inlet 1/4", Outlet 1/4" both 316 SS.
- Rigorous 100% performance and burn-in tests of all electrical connections are conducted at elevated operating temperature to insure the highest level of product **quality** and **reliability.**
- Pre-seasoned and performance tested to insure the highest level of product **quality** and **reliability.**
- Military grade conformal coating eliminates problems associated with condensation and mold as well as greatly retarding damage caused by accidental ozone exposure.

INSTALLATION AND OPERATION OF Plasma BLO₃CK® COMPLETE ASSEMBLIES INVERTER AND CELL

Section 1. GENERAL MOUNTING REQUIREMENTS

1. Mount to allow O₂ flow meters to work for user feedback. The assembly contains a cooling fan which cools the transformer. Allow 1.25" to 1.5" clearance between the top of the fan and an enclosure surface.
2. Read the nameplate for operating line voltage and current adjustment levels. **Use copper conductors only.**
3. Apply only the line voltage indicated on the nameplate.
4. Ground the plate assembly to service green utilizing star washer. **See installation drawing on the product drawings for possible grounding locations and High Voltage safety considerations..**
5. It is **important** to at least **verify** that the **system is set to the proper pressure**. If the pressure is below 5 psi **DO NOT** apply power. A vacuum condition in the generator cell will cause it to fail.
6. Since the generator is set up at the factory for maximum power under varying conditions of mains voltage and gas pressure or flow, if the mains power specified for this generator varies by more than 10% at full load, the inverter should be readjusted as shown in the DAT210 manual.

Mounting Environment

The block should be mounted in an environment that is **free** from the following:

Corrosive or volatile vapors

Dust and particles

Excessive moisture

Shock, Excessive vibration

Temperature extremes

The following environmental specifications apply:

Relative humidity: 5 to 90%, non-condensing. Altitude (maximum): 3,310 ft (1,000 m), de-rating for altitude is 1% for every 300 ft (100m) above 3000 ft (1000m).

Mounting can be in **any axis**.

Pressure and flow requirements are the same as all other Plasma Block® products. Connect oxygen feed gas to port labeled INLET. OUTLET should have a flow restriction control downstream to produce an operating pressure range of 5 to 100 psi.

Allow 1" (2.5 cm) **MINIMUM** of space around the fan and areas which vent cooling air. 2" (5 cm) is better.

Surrounding air ambient operating temperature: 0° to 40° C (32° to 104° F)

No heat inducing stray fields are to be present within 3 feet (1 M) of the unit. These fields can radiate from large motors or large power supplies in the KW range.

Section 2

Wiring Standards and Codes

The installation person is responsible for following the wiring plan produced by the design engineer for the specific application.

All wiring must conform to the following standards:

National Electrical Code, Publication NFPA No. 70.

All local and national codes which apply. For motor usage; use appropriate NEMA relay for protection.

The supplier cannot assume responsibility for the compliance or noncompliance to any code governing the proper installation of this equipment.

Electrical Connection Wire Sizing and Fusing

The DAT210 input current ratings: 45g = 6.3 amps RMS at 115 VAC (3.0 Amps at 240 VAC). See graphs for complete power adjustment data. Use branch circuit fuses suitable for use on a circuit capable of delivering not more than 10 A RMS Slo-Blo, 250 volts maximum. Refer to the National Electrical Code[NEC], Publication NFPA No. 70, Article 310, and any local codes that may apply for wire sizing and selection. Use 60/75°C wire min. Use copper conductors only.

Terminal connection max torque .37 inch lbs [0.5 newton meters (Nm)].

Case Ground

Each of the blocks must be connected to ground at their case ground terminal. A grounding electrode conductor or bonding jumper must be connected from the ground terminal to either a grounding electrode buried in the earth or a suitable plant ground with solid connections to earth ground. Refer to NFPA No. 70, Article 250, for details on grounding and grounding electrodes.

Safety Grounding

The case ground connections should be made at the ground terminals. The case ground of the various system components should be connected to the star grounding bus of the cabinet. A grounding electrode conductor or bonding jumper must be connected from the star grounding bus to either a grounding electrode buried in the earth or a suitable plant ground with solid connections to earth ground. Refer to NFPA No. 70, Article 250, for details on grounding and grounding electrodes.

The only external connections for control needed are the ON/OFF switch. Note that an OFF contact closure will shut off the inverter even if the ON contact is made. The OFF contact takes priority.

All adjustments can be made on the inverter as shown with the jumper positions shown at the INTERNAL CONTROL position. The VOLTAGE and FREQUENCY are pre-adjusted to your purchase order specifications. Power adjustment is by the PDM potentiometer only for normal operation 0 – 100%. PDM may be changed to EXTERNAL for output control in your final equipment.

115 VAC wiring should be rated 10 Amps.

There MUST be a green wire earth ground from the chassis to conduit ground. This is an important safety and reliability feature.

Section 3 General Operating Considerations

1. Since the current requirement is relatively low (6.3 A at 115 VAC for 45 g/hr), 115 VAC mains is typical. Special configurations are necessary for 240 VAC mains voltage.
2. When AC power is applied, an inrush will occur - this is normal. A typical system will require a 10-amp circuit breaker. If the inverter line voltage will be turned on frequently the relay or switch should be amply sized to prolong its life due to the high inrush current. A soft charge circuit is recommended or p/n 70258 DIN rail module could be used. The circuit can be found in the DAT210 operator's manual. This will also extend the life of the DAT210 components.
3. The Plasma Block® is built with aluminum and ceramic. While aluminum provides maximum safety for applications like water purification, it does react with nitric acid that would be produced if atmospheric air were to be used rather than a concentrate for gas feed. For this reason **ONLY a concentrator or O₂ can be used to provide the feed gas.** To maintain the warranty the feed gas must be at least -60°F dew point and 93% O₂ or more.

4. **BEFORE** the system is energized for the first time the Plasma Block® should pre-dried by flowing the above feed gas for 3 to 5 minutes. If the installed system will be dormant for long intervals then the control system should do a pre-purge to insure the system is dry before power is applied to the cell.
5. When a system is off for an extended period, it is very important to prevent backflow of liquids and gasses through the cell. Backflows void the cell warranty. For example, systems which use a venturi and concentrator must contain a solenoid valve to block gas flow if it is possible that the venturi will be active while the concentrator is off.
6. When the Block requires servicing, return it to the factory - DO NOT disassemble. The Plasma Block® is fitted with a tamper label. If the label is broken, the warranty is void.
7. **While it is possible to configure the system to accommodate negative pressures, negative pressures are problematic and tend to cause large power and ozone fluctuations. The most stable and predictable systems occur at positive pressures.**
8. The ozone outlet fitting mounted into the plasma block® mates with other fittings inside of the unit and **must not be removed or changed** to another fitting type. Contact the factory if other sizes or styles are required.

Safety Considerations

DANGEROUS VOLTAGES ARE ON THIS CIRCUIT BOARD

To avoid injury to personnel and/or damage to equipment only qualified personnel should perform the procedures outlined in this chapter. This person must understand both the electrical and mechanical components associated with the application.

Thoroughly read and understand the following procedures before beginning the start-up process.

The following specific safety procedures must be observed when performing any maintenance or adjustments on the amplifier.

Always turn off and lock out AC power at the main machine disconnects switch. Do this before touching any electrical or mechanical components.

High voltage may be present even with all electrical power supplies disconnected.

Use an appropriate meter to verify that all DC bus capacitor banks have been discharged before working on any equipment. Do not rely exclusively on high voltage RED LED indicator for bus voltage, as dangerous voltage levels may remain even when the indicator is off.

Follow industry recognized safety procedures. Use only one hand to hold test equipment probes, wear approved eye protection, etc. Before energizing the inverter, make sure that device(s) connected to the output of the inverter will not result in injury or damage to equipment. Keep unnecessary personnel out of the immediate work area. Never leave an inverter cabinet open and unattended.

Start-up Checklist

To ensure a complete checkout and test, check off each step as it is completed. If the proper event does not occur while performing this start-up procedure, do not continue. Take the appropriate action to correct the malfunction before proceeding.

- Ensure the main disconnect switch is locked off. High voltage may be present even with all electrical power supplies are disconnected. Use an appropriate meter to verify that all DC bus capacitor banks have been discharged before working on any equipment. Do not rely exclusively on RED LED indicator of bus voltage, as dangerous voltage levels may remain even when indicator is off.
- Verify that the inverter mounting has been performed in accordance with the guidelines listed in Section 1.
- Inspect the inverter to verify that all optional modules have been selected and installed according to the system drawings and documentation.
- Verify that all wiring has been installed according to the wiring plan produced by the design engineer and according to the guidelines listed in Section 2 for proper connection, grounding, wire size, labeling, routing and applicable codes. The DAT 210 does not have internal fusing. Install input and output (optional) fusing per suggestions Page 23.
- Verify that all electrical terminals, screws, nuts, and bolts are securely fastened.
- Apply high voltage DC or single-phase AC power to the inverter as specified.
- Check to make sure that the RED Bus voltage LED is on, indicating bus voltage.

Section 4 Changing the factory power configuration

START-UP PROCEDURE POWER ADJUSTMENT

Reasons for changing the factory setup:

By altering the 'Voltage' setting, you can easily modify the full power operational point if need be. Remember that the purpose of the PDM control is to provide a turndown from the 100% power set-point established by the **VOLTAGE** pot. The goals are 1) Maximum power and 2) Current High/Low limits. Adjustment is very easy.

If it is determined that the Plasma Block[®] has much more ozone output than the application requires. You would know this if, for example, if the closed loop control from an ORP unit always had the PDM adjusted to a very low value of current, like 6-10ma.

OR

A PlasmaBlock[®] is going to be applied at pressure and flow range that is different from the factory setup.

REMOVE POWER FROM THE INVERTER FOR SET UP

1. **Install a true RMS current clamp-on meter** to one of the mains AC power wires, terminals 1 or 2 of Connector 2. A power meter could also be used.
Note: An inexpensive and surprisingly accurate power meter can be purchased for \$25-\$35: UPM model EM100 or Kill-A-Watt from P3 International.
2. **PDM should be set at 100%.** Another method of turning the PDM to full ON if it is more convenient is to turn **Switch S1** OFF. This forces the PDM at 100%.
3. **Verify Switch S4 and S5 OFF:** fault enable. This will prevent any faults, current exceeding the High/Low limits for example, from shutting down the unit while it's being adjusted.

Note: Maximum power safety is now OFF. It is possible to damage the ozone cell.

4. **Pull jumper J5 AUTO**, which will select the **Semi-Auto** mode and allow the **VOLTAGE** pot (potentiometer) to be manual active. The frequency will still be automatically adjusted for resonance.
5. **Turn the VOLTAGE pot counterclockwise (CCW)** until clicking sound indicates minimum.

APPLY POWER TO THE INVERTER – TURN THE INVERTER ON

6. **Adjust the VOLTAGE pot CW** to the desired maximum current (power) level permissible. Ozone levels alone can also be used to establish maximum power if satisfactory at a lower current (power). The processor continues to optimize other aspects of the tuning process as indicated by the occasional 'wink' of the **LOCKED** (resonant frequency found) LED. If the **VOLTAGE** control is increased excessively (pot CW), and a safety limit is reached, the pair of Red LEDs will **flash rapidly** in an alternating manor. This will not damage the ozone cell. Simply **reduce** (CCW) the voltage **control** to an acceptable level of current (power) and the LEDs will extinguish.
7. **Set the High/Low power limits.**
 - Push the **OP_OK** push switch once (1 to 5 seconds). Two Yellow LEDS will come on and blink slowly. This is the +/- 40% power fault tolerance limits.
 - Push **OP_OK** once again. The Yellow LEDS will flash faster. This is the +/- 20% limit.
 - Push **OP_OK** once again. The Yellow LED will flash even faster. This is the +/- 10% limit.
 - Keep pushing **OP_OK** and the cycle repeats.
 - The normal factory recommended limit is +/- 20% (40% total).
8. Lock in the new operating point by **pushing and hold the 'Op_OK' button until the Red LEDs come ON**. Then release it. Then ALL the LEDs will come ON (except FAULT) momentarily to acknowledge your input and the inverter will turn OFF. This action permanently stores the new parameters in the processors memory and causes a reboot of the unit.
9. Set Switches **S1, S4** and **S5** to ON. Reinstall **J5** (AUTO_Tune). Re-enable by cycling the inverter OFF and ON.
10. Now observe the inverter gradually increase power to the new programmed level automatically at 100% PDM. Frequency control is automatic and the **LOCKED** LED will cycle indicating frequency lock. The inverter PDM can now control power from 1% to the 100% new programmed value.

You should now observe that the PDM level (power control) being commanded from the ORP unit is much greater, for example, hence making the control loop more stable.

OR

The inverter is now properly configured for new pressure or flow ranges.

Section 5 Performance Graphs

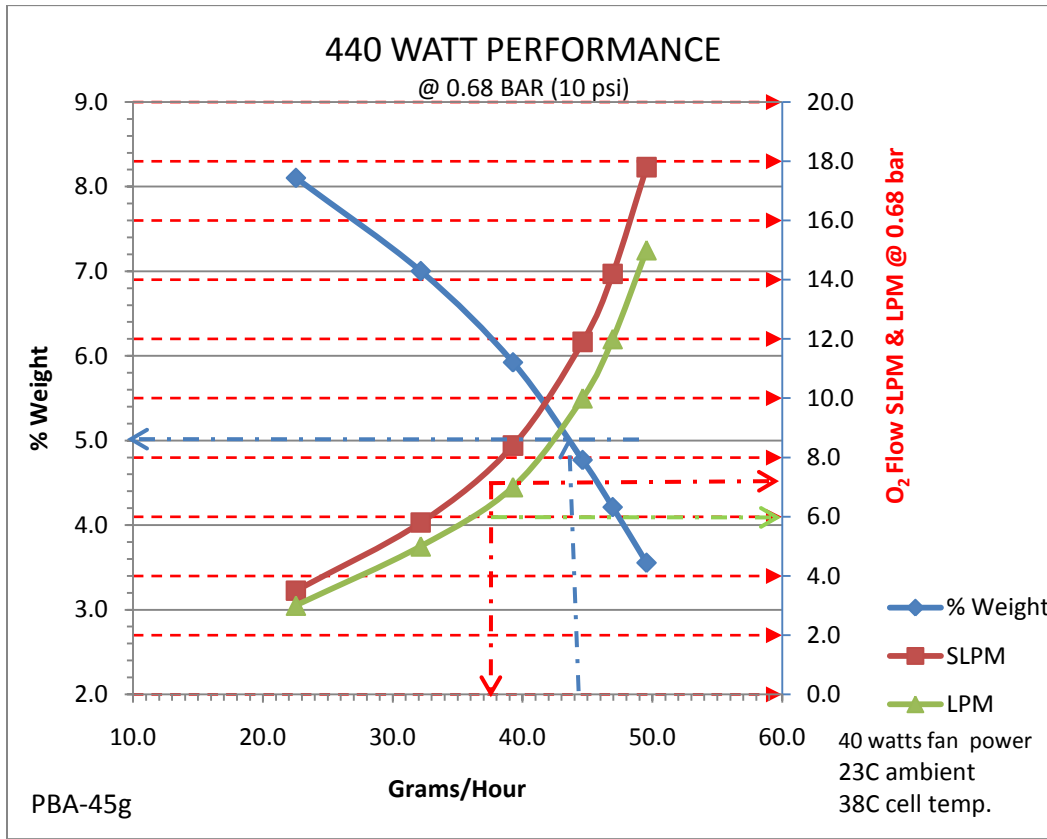

Normal factory POWER set point: 440 watts at FULL PDM (10vdc or 20ma).
 Published production-ozone output level (45 gr/hr) based on 5% concentration.
 Tests conducted at 23C (74°F), 700' (213 M) MSL: Ozone in g/nm³.
 Flow measured in LPM via **uncorrected** Rotameter at inlet port.
 Fan and power supply burden of 40 watts is included in above chart.

Procedure 1, Grams per hour desired at maximum power:

1. Determine the Grams/Hr desired for the chemical reaction. 45 gram/hr for this example.
2. Moving vertically from the value on the horizontal scale at 45 gr/hr, note the % weight (Blue line) on the left axis at 5 % wt for the maximum power at 45 gr/Hr.
3. At the same Grams/hr value move vertically and note both the SLPM at 10.5 SLPM (red) and indicated LPM (green) at 8.5 LPM at the recommended pressure [0.68 bar (10 psi)] on the right vertical axis.
4. If a higher % weight is desired at the Grams/Hr needed, a larger generator must be selected. A generator can always be run at a lower power than maximum with the PDM control.

Procedure 2 example, Oxygen flow of 6 LPM maximum at 0.68 bar (10 psi) on a rotameter. What is the maximum gr/hr production?

1. Start on the right vertical scale at 4 LPM rotameter reading. Move horizontally to intercept the green LPM line at 6 LPM.
2. Drop down vertically to see what gr/hr is available. It is 37 gr/Hr in this case.
3. Move vertically to intercept the red SLPM line at 7 SLPM and the blue % wt line at 6.2 % wt.

Section 6

Installation Drawing: Inches

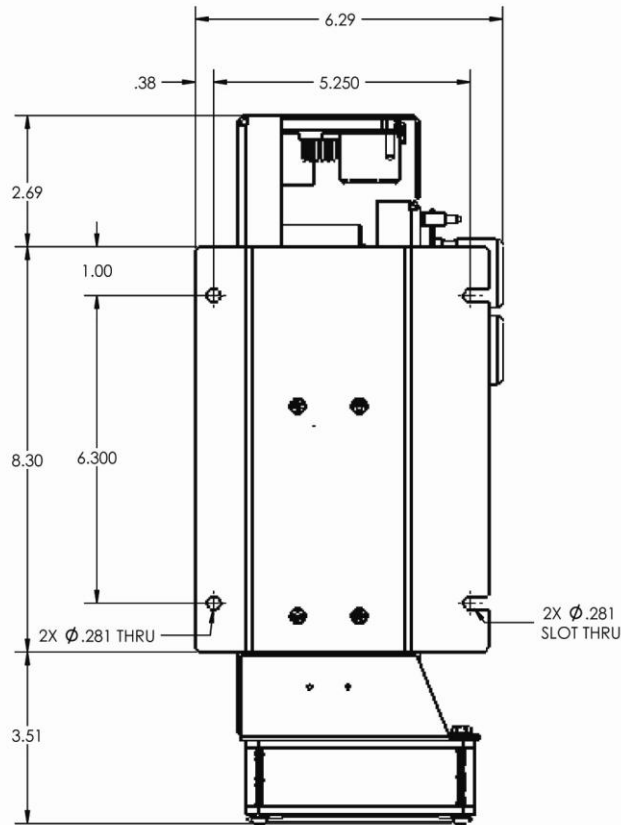

**Bottom View
Standard Mount**



**End View
Standard Mount**

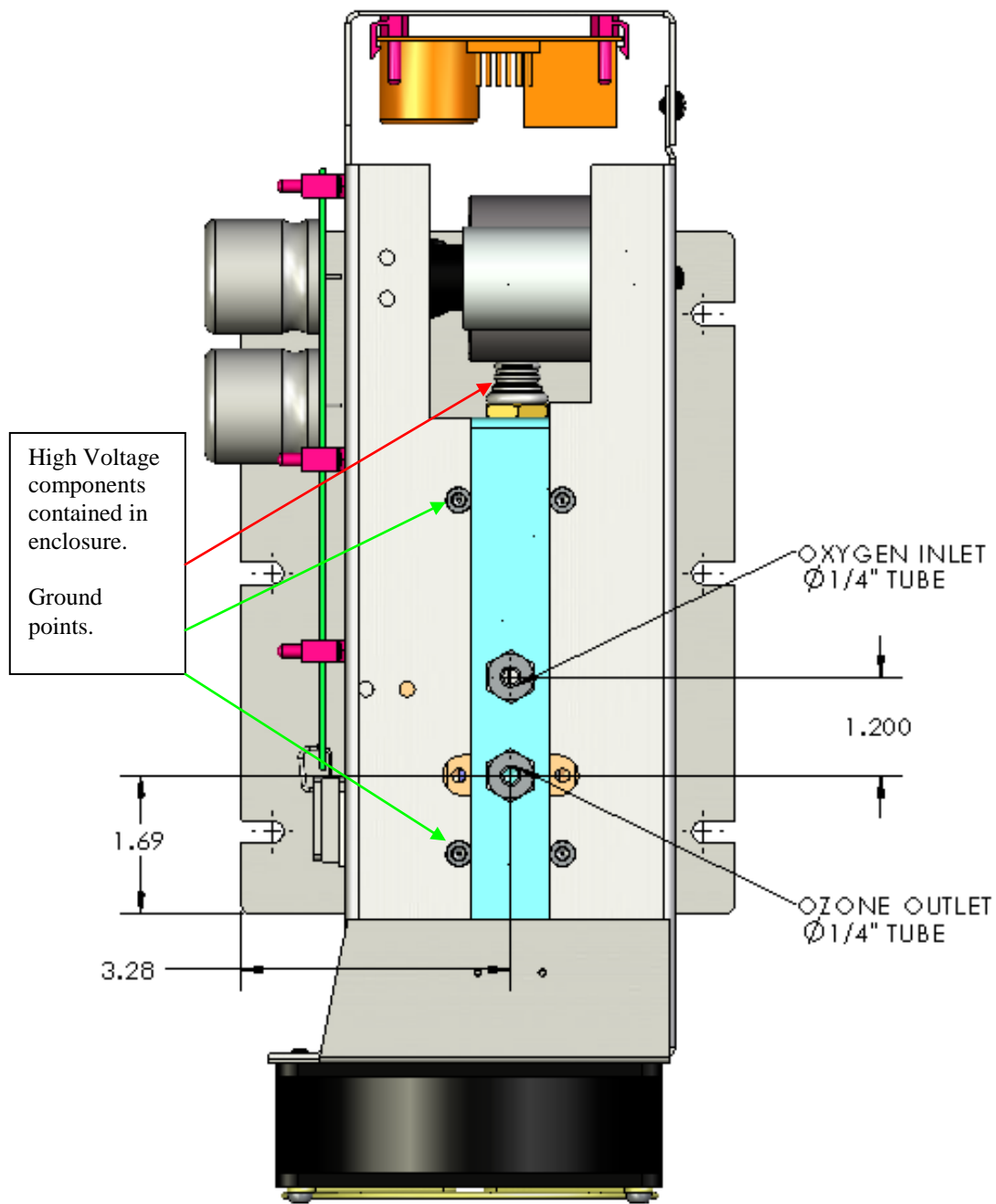

**Top View
Standard Mount**

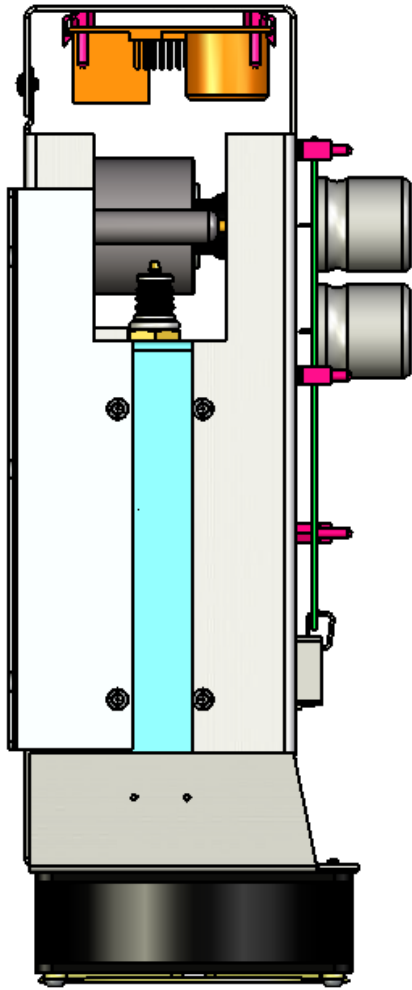

**Side View
Alternate Mount**

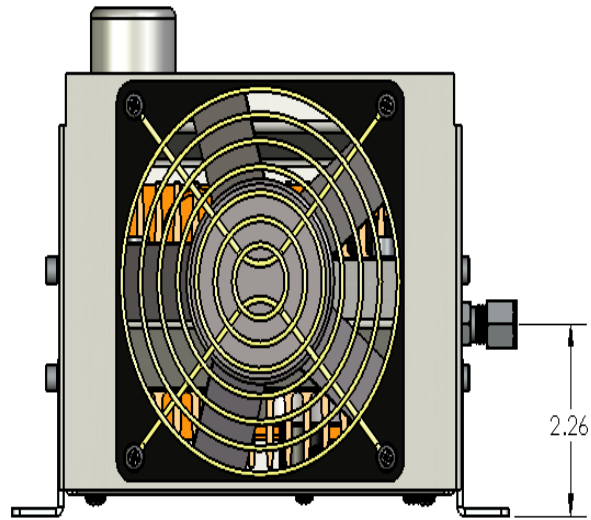

**End View
Alternate Mount**